

Description

- Complex type bipolar transistor

Feature

- Small package save PCB area
- Reduce quantity of parts and mounting cost
- Two 2SA1980 chips in SOT-363 package

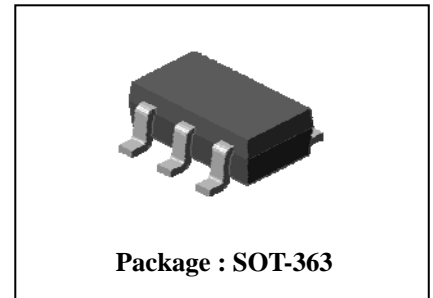

Ordering Information

Type NO.	Marking	Package Code
SUT487J	XX□	SOT-363

□ : Year & Week Code

Equivalent circuit & PIN Connections

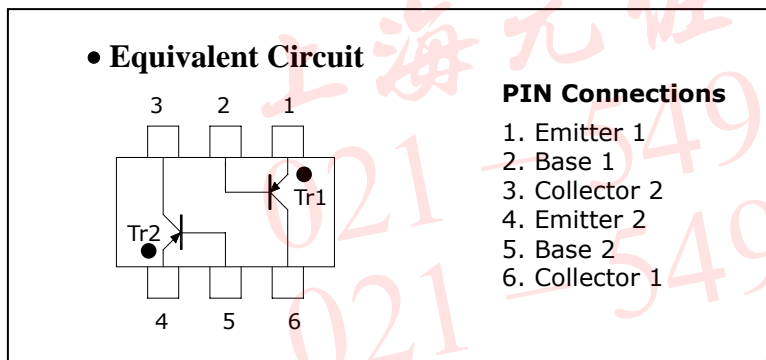

Absolute Maximum Ratings [Tr1, Tr2]

(Ta=25°C)

Characteristic	Symbol	Rating	Unit
Collector-base voltage	V_{CBO}	-50	V
Collector-emitter voltage	V_{CEO}	-50	V
Emitter-base voltage	V_{EBO}	-5	V
Collector current	I_C	-150	mA
Collector power dissipation	P_C^*	200	mW
Junction temperature	T_J	150	°C
Storage temperature range	T_{stg}	-55~150	°C

※: Total rating

Electrical Characteristics [Tr1,Tr2]

(Ta=25°C)

Characteristic	Symbol	Test Condition	Min.	Typ.	Max.	Unit
Collector-emitter breakdown voltage	BV_{CEO}	$I_C = -1\text{mA}, I_B = 0$	-50	-	-	V
Collector cut-off current	I_{CBO}	$V_{CB} = -50\text{V}, I_E = 0$	-	-	-0.1	μA
Emitter cut-off current	I_{EBO}	$V_{EB} = -5\text{V}, I_C = 0$	-	-	-0.1	μA
DC current gain	h_{FE}	$V_{CE} = -6\text{V}, I_C = -2\text{mA}$	120	-	400	-
Collector-emitter saturation voltage	$V_{CE(sat)}$	$I_C = -100\text{mA}, I_B = -10\text{mA}$	-	-	-0.3	V
Base-emitter voltage	V_{BE}	$V_{CE} = -6\text{V}, I_C = -2\text{mA}$	-	-0.65	-	V
Transition frequency	f_T	$V_{CE} = -10\text{V}, I_C = -10\text{mA}$	-	200	-	MHz
Collector output capacitance	C_{ob}	$V_{CB} = -10\text{V}, I_E = 0, f = 1\text{MHz}$	-	4	-	pF

Electrical Characteristic Curves

[Tr1, Tr2]

Fig. 1 $I_C - V_{BE}$

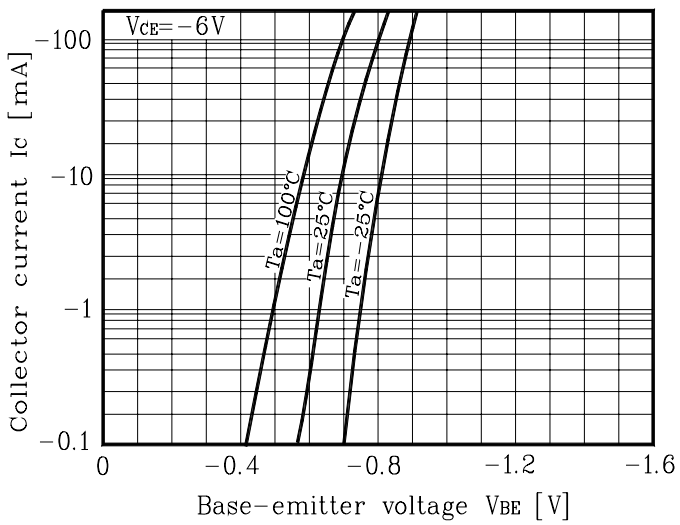

Fig. 2 $I_C - V_{CE}$

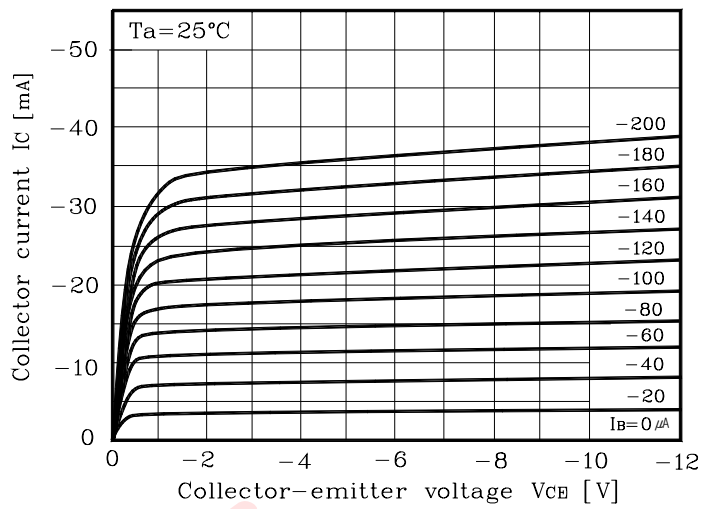

Fig. 3 $h_{FE} - I_C$

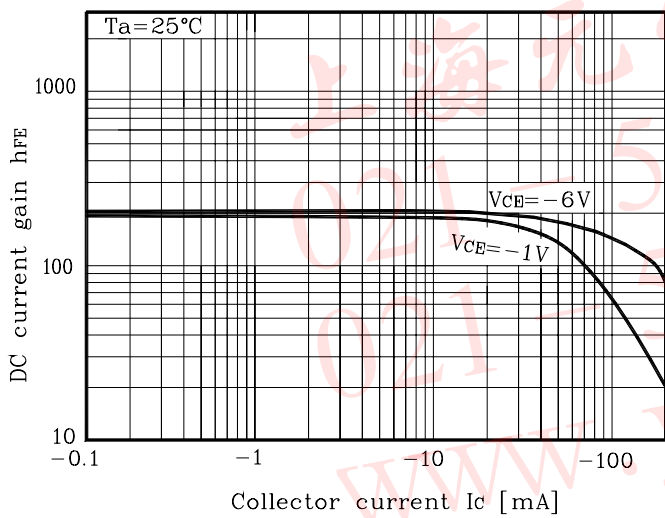

Fig. 4 $V_{CE(sat)} - I_C$

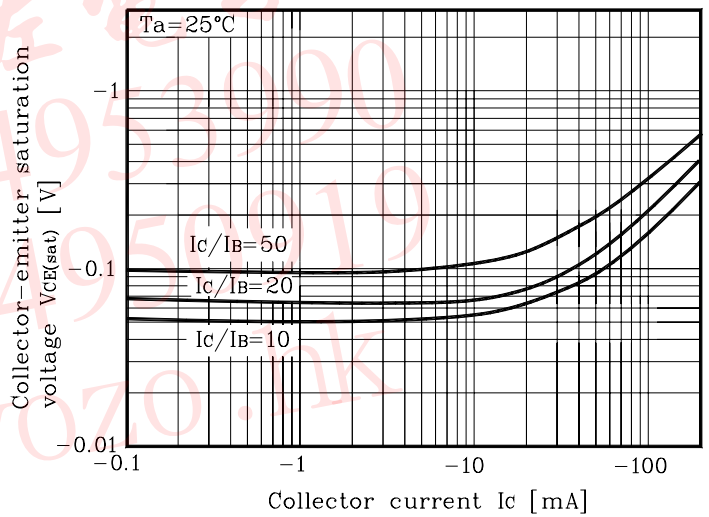
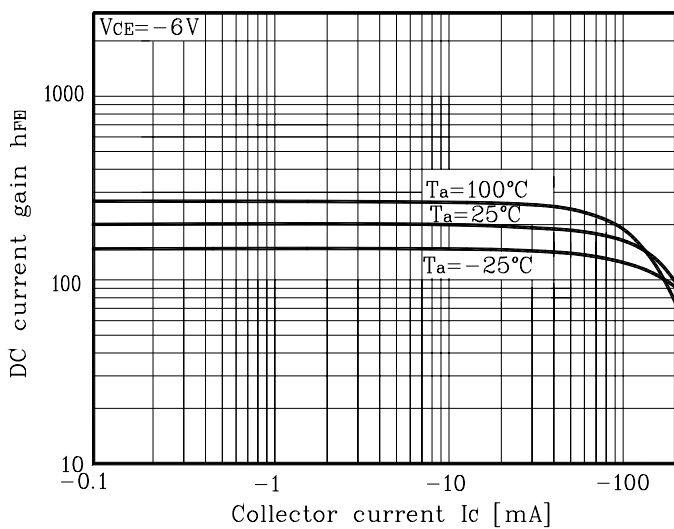
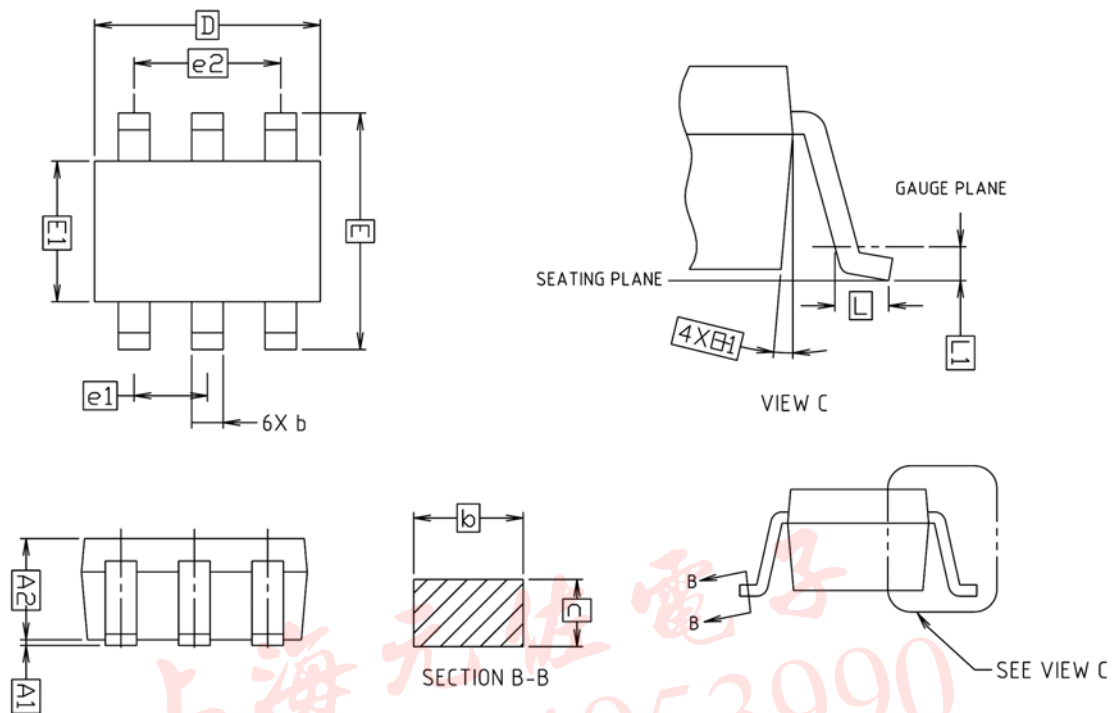

Fig. 5 $h_{FE} - I_C$



Outline Dimension



SYMBOL	MILLIMETERS			NOTE
	MINIMUM	NOMINAL	MAXIMUM	
A1	0.00	-	0.10	
A2	0.90	0.95	1.00	
b	0.25	-	0.40	
c	0.10	-	0.25	
D	1.90	2.00	2.10	
E	1.95	2.10	2.25	
E1	1.15	1.25	1.35	
e1		0.65 BSC		
e2		1.30 BSC		
L	0.25	-	-	
L1		0.15 BSC		

※ Recommend PCB solder land [Unit: mm]

