

SWITCHING REGULATOR APPLICATIONS

Features

- High Voltage: $BV_{DSS}=500V(\text{Min.})$
- Low C_{RSS} : $C_{RSS}=23pF(\text{Typ.})$
- Low gate charge : $Q_g=36nC(\text{Typ.})$
- Low $R_{DS(on)}$: $R_{DS(on)}=0.48\Omega(\text{Max.})$

Ordering Information

Type No.	Marking	Package Code
SMK1350F	SMK1350	TO-220F-3L

PIN Connection

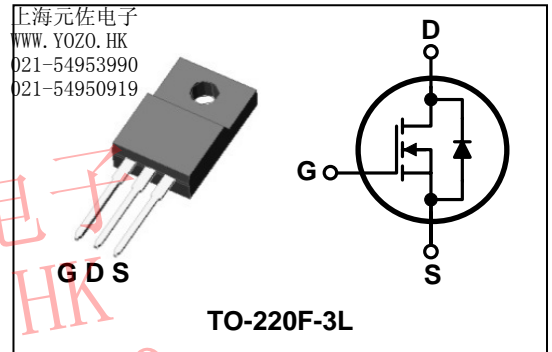

Absolute maximum ratings ($T_c=25^\circ\text{C}$ unless otherwise noted)

Characteristic	Symbol	Rating	Unit
Drain-source voltage	V_{DSS}	500	V
Gate-source voltage	V_{GSS}	± 30	V
Drain current (DC)*	I_D	($T_c=25^\circ\text{C}$)	13
		($T_c=100^\circ\text{C}$)	8.2
Drain current (Pulsed)*	I_{DM}	52	A
Drain power dissipation	P_D	40	W
Avalanche current (Single) ②	I_{AS}	13	A
Single pulsed avalanche energy ②	E_{AS}	751	mJ
Avalanche current (Repetitive) ①	I_{AR}	13	A
Repetitive avalanche energy ①	E_{AR}	19.5	mJ
Junction temperature	T_J	150	$^\circ\text{C}$
Storage temperature range	T_{stg}	-55~150	

* Limited by maximum junction temperature

Characteristic	Symbol	Typ.	Max	Unit
Thermal resistance	Junction-case	-	3.12	$^\circ\text{C}/\text{W}$
	Junction-ambient	-	62.5	

Electrical Characteristics ($T_C=25^\circ\text{C}$ unless otherwise noted)

Characteristic	Symbol	Test Condition	Min.	Typ.	Max.	Unit
Drain-source breakdown voltage	BV_{DSS}	$I_D=250\mu\text{A}, V_{GS}=0$	500	-	-	V
Gate threshold voltage	$V_{GS(th)}$	$I_D=250\mu\text{A}, V_{DS}=V_{GS}$	2.0	-	4.0	V
Drain-source cut-off current	I_{DSS}	$V_{DS}=500\text{V}, V_{GS}=0\text{V}$	-	-	1	μA
Gate leakage current	I_{GSS}	$V_{DS}=0\text{V}, V_{GS}=\pm 30\text{V}$	-	-	± 100	nA
Drain-source on-resistance ④	$R_{DS(on)}$	$V_{GS}=10\text{V}, I_D=6.5\text{A}$	-	0.4	0.48	Ω
Forward transfer conductance ④	g_{fs}	$V_{DS}=10\text{V}, I_D=6.5\text{A}$	-	15	-	S
Input capacitance	C_{iss}	$V_{GS}=0\text{V}, V_{DS}=25\text{V}$ $f=1\text{MHz}$	-	1960	2450	pF
Output capacitance	C_{oss}		-	190	237	
Reverse transfer capacitance	C_{rss}		-	23	29	
Turn-on delay time	$t_{d(on)}$	$V_{DD}=300\text{V}, I_D=12\text{A}$ $R_G=25\Omega$	-	25	-	ns
Rise time	t_r		-	100	-	
Turn-off delay time	$t_{d(off)}$		-	130	-	
Fall time	t_f		-	100	-	
Total gate charge	Q_g	$V_{DS}=400\text{V}, V_{GS}=10\text{V}$ $I_D=13\text{A}$	-	36	45	nC
Gate-source charge	Q_{gs}		-	8.3	-	
Gate-drain charge	Q_{gd}		-	9.8	-	

Source-Drain Diode Ratings and Characteristics ($T_C=25^\circ\text{C}$ unless otherwise noted)

Characteristic	Symbol	Test Condition	Min	Typ	Max	Unit
Source current (DC)	I_S	Integral reverse diode in the MOSFET	-	-	13	A
Source current (Pulsed) ①	I_{SM}		-	-	52	
Forward voltage ④	V_{SD}	$V_{GS}=0\text{V}, I_S=13\text{A}$	-	-	1.4	V
Reverse recovery time	t_{rr}	$I_S=12\text{A}, V_{GS}=0,$ $di_S/dt=100\text{A}/\mu\text{s}$	-	410	-	ns
Reverse recovery charge	Q_{rr}		-	4.5	-	μC

上海元佐电子
WWW.YOZO.HK
021-54953990
021-54950919

Note ;

- ① Repetitive Rating : Pulse Width Limited by Maximum Junction Temperature
- ② $L=8.0\text{mH}, I_{AS}=13\text{A}, V_{DD}=50\text{V}, R_G=25\Omega$, Starting $T_J = 25^\circ\text{C}$
- ③ Pulse Test : Pulse Width < 300us, Duty cycle $\leq 2\%$
- ④ Essentially independent of operating temperature

Electrical Characteristic Curves

Fig. 1 $I_D - V_{DS}$

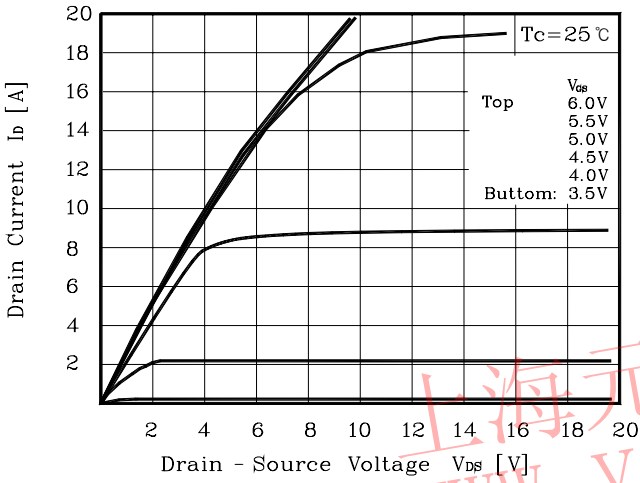

Fig. 2 $I_D - V_{GS}$

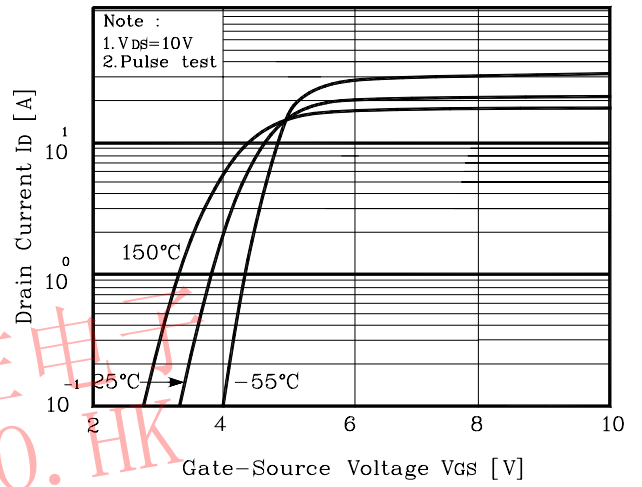

Fig. 3 $R_{DS(on)} - I_D$

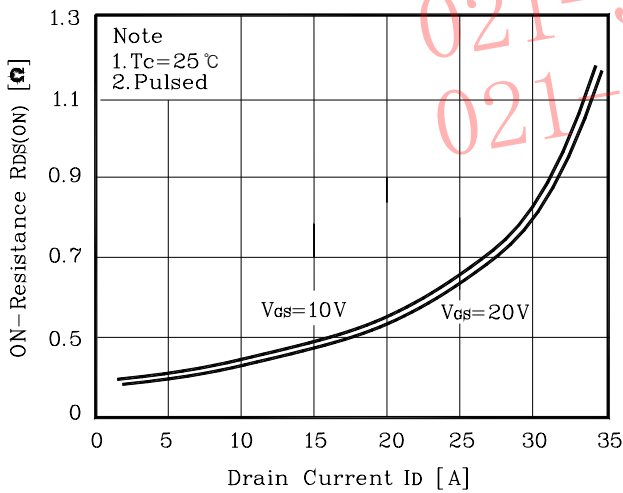

Fig. 4 $I_S - V_{SD}$

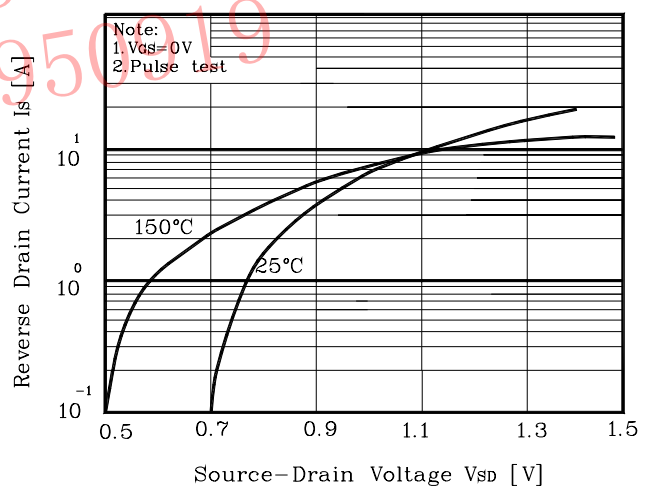

Fig. 5 Capacitance - V_{DS}

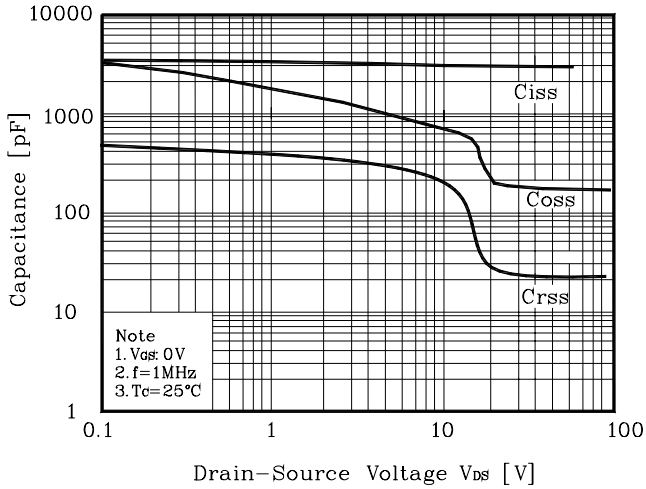
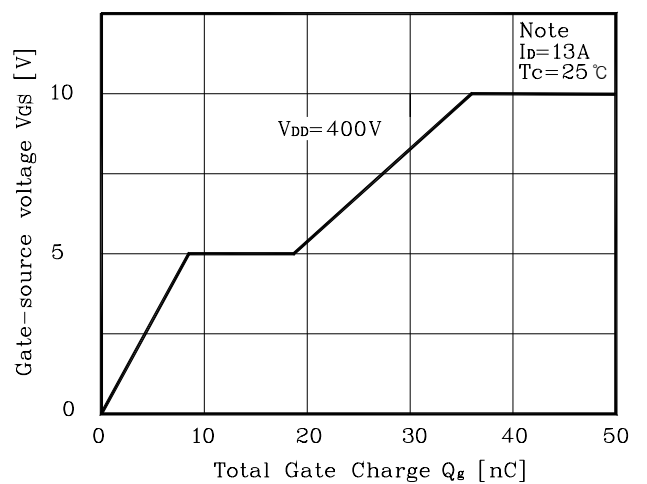

Fig. 6 $V_{GS} - Q_G$



Electrical Characteristic Curves

Fig. 7 $V_{DSS} - T_J$

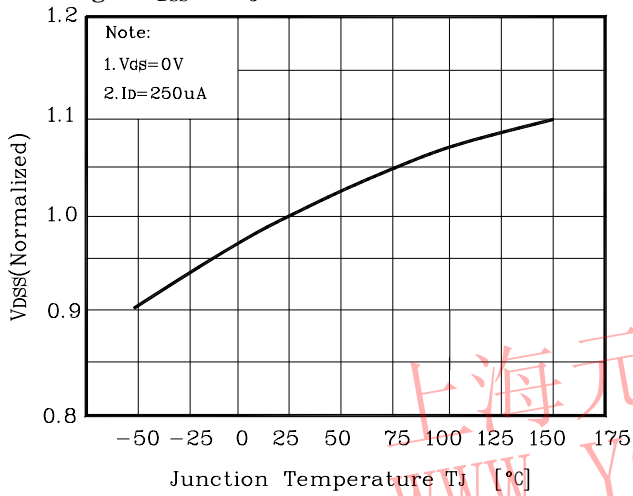

Fig.8 $R_{DS(on)} - T_J$

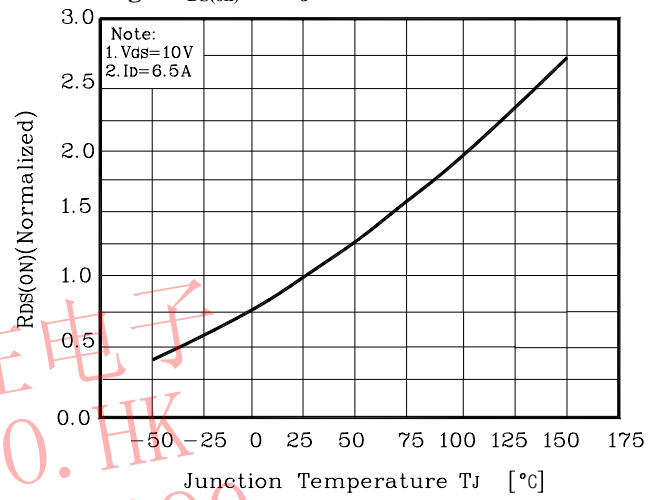

Fig. 9 $I_D - T_C$

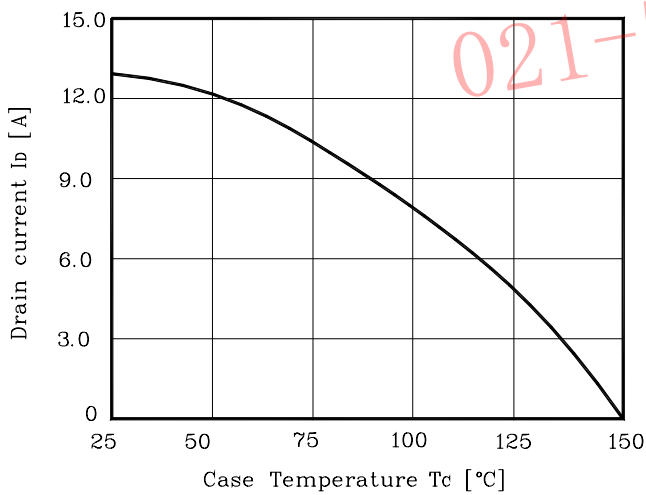

Fig. 10 Safe Operating Area

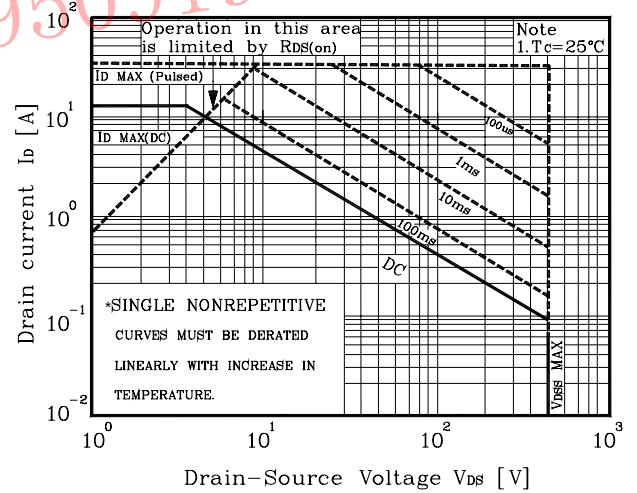

Fig. 10 Gate Charge Test Circuit & Waveform

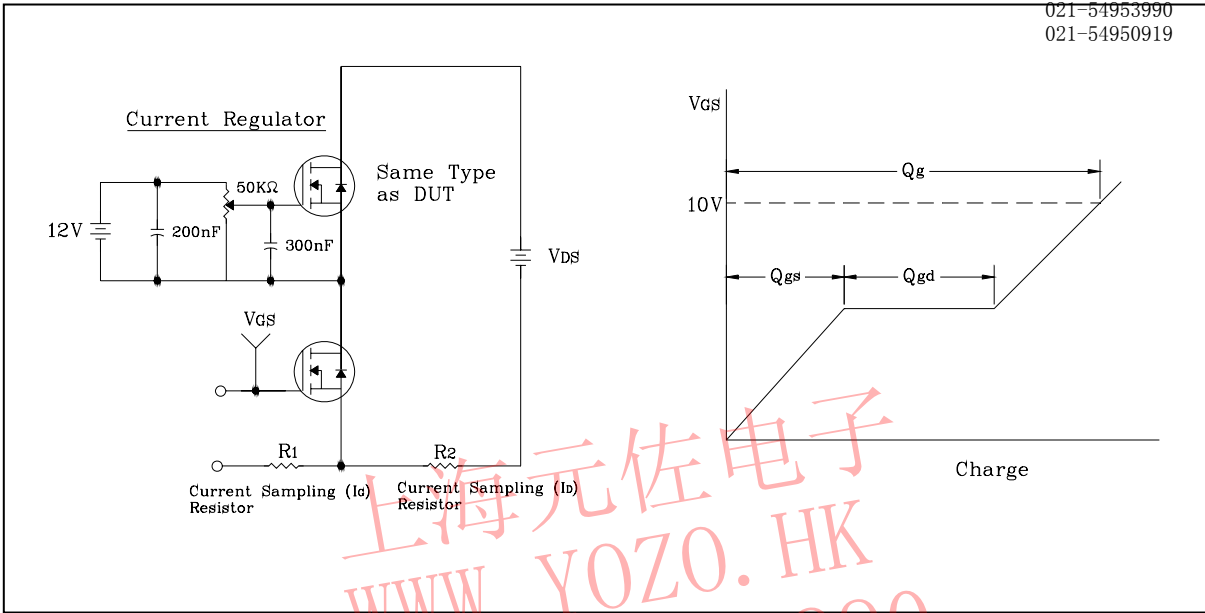

Fig. 11 Resistive Switching Test Circuit & Waveform

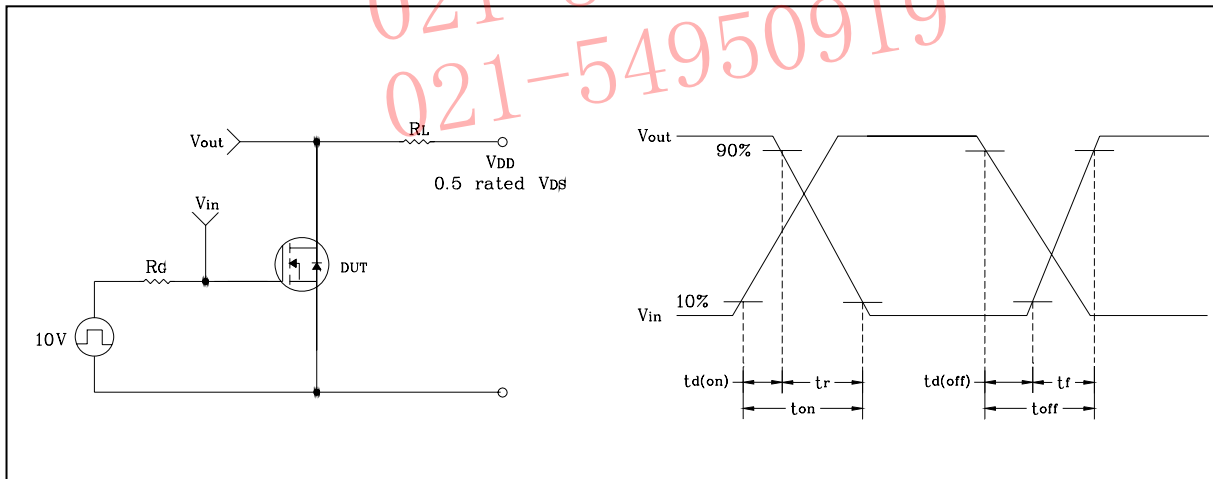

Fig. 12 E_{AS} Test Circuit & Waveform

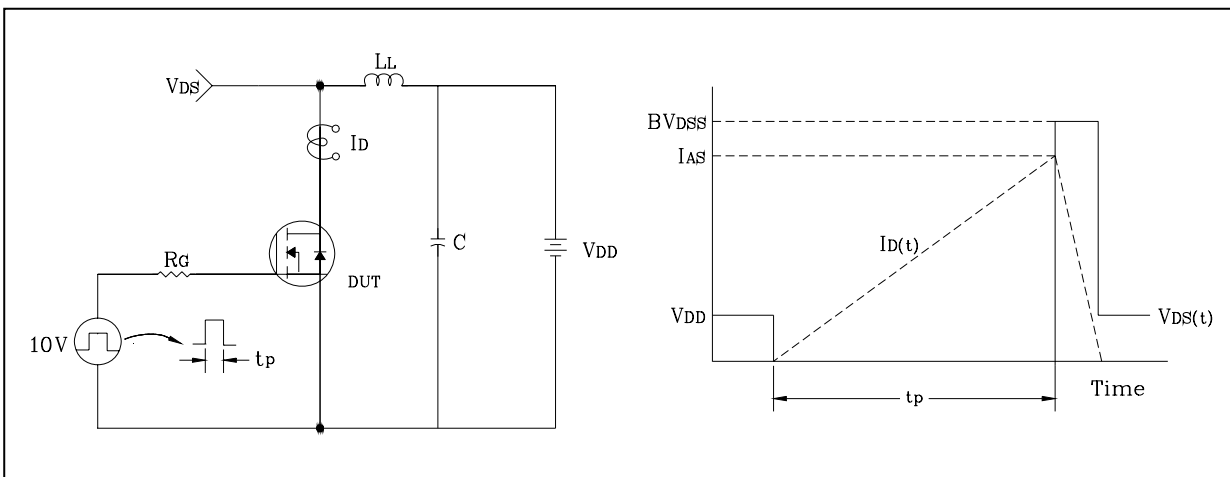
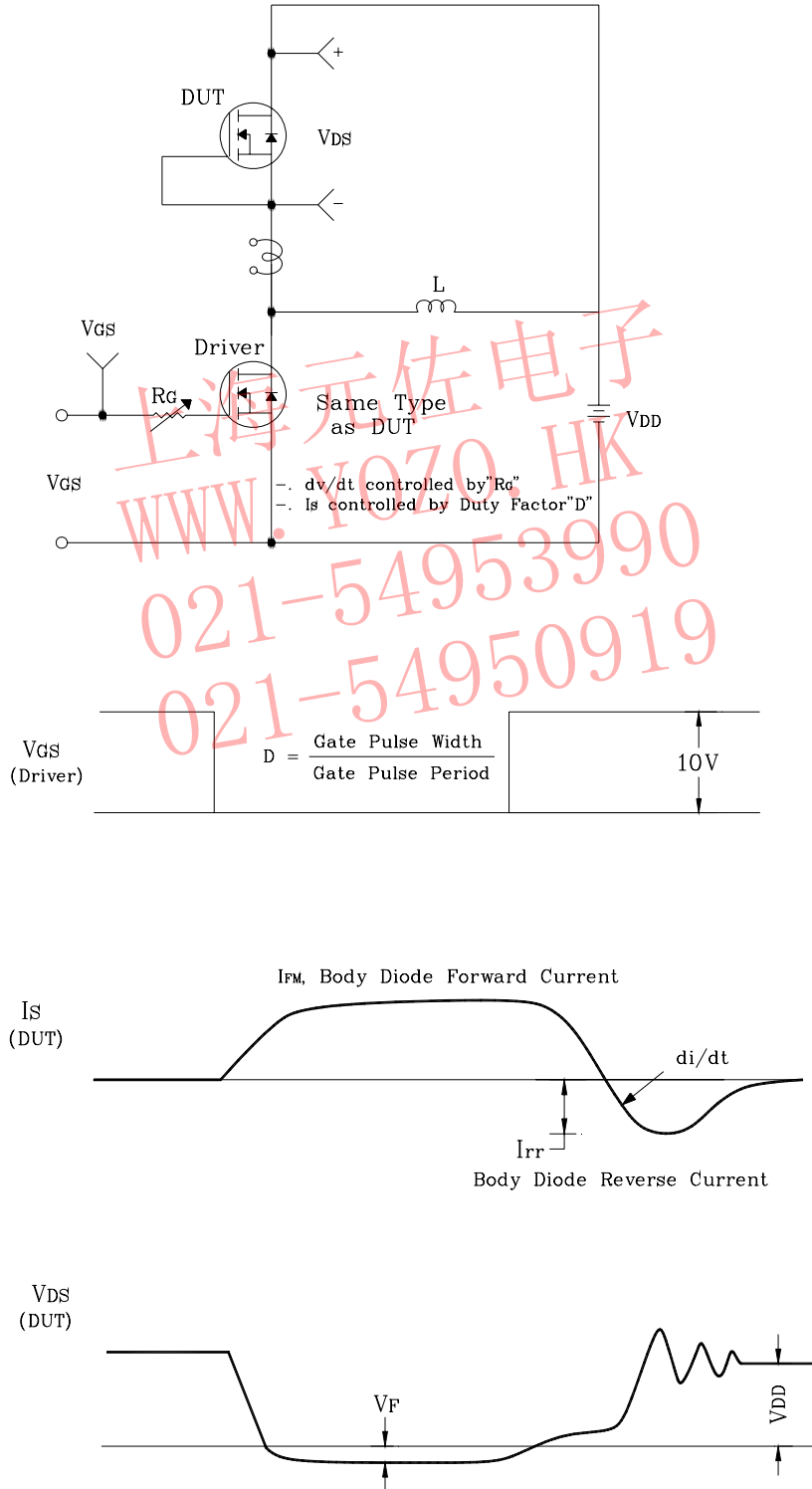
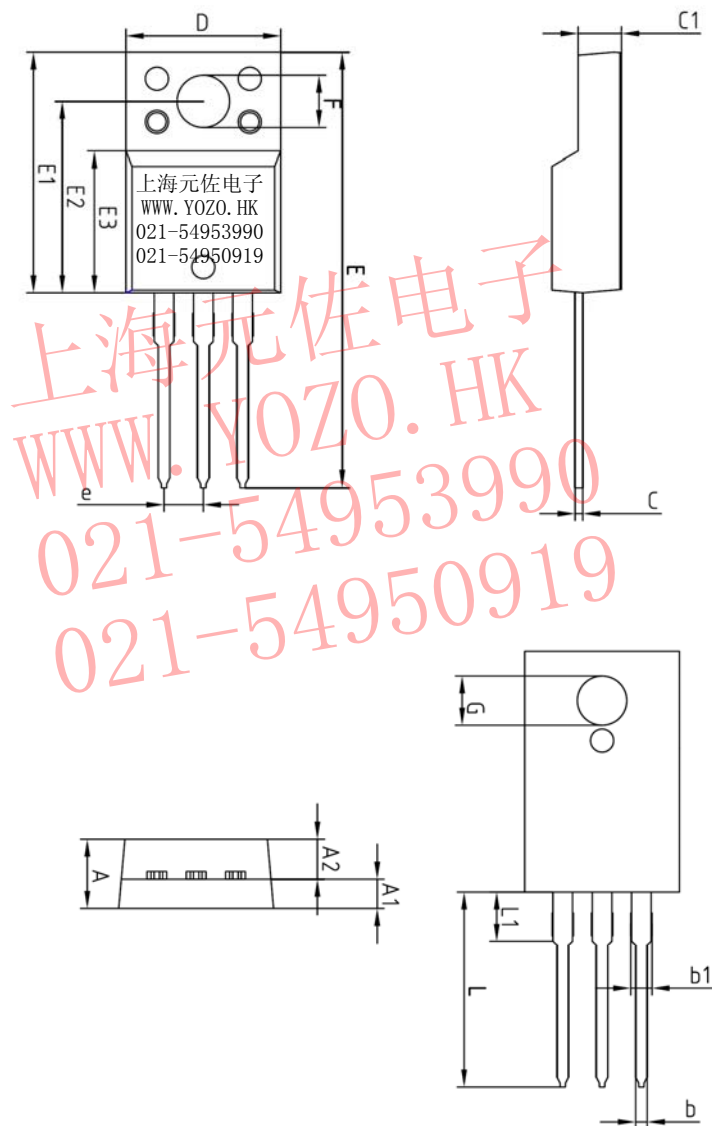

Fig. 13 Diode Reverse Recovery Time Test Circuit & Waveform



Outline Dimension



SYMBOL	MILLIMETERS			NOTE
	MINIMUM	NOMINAL	MAXIMUM	
A	-	-	4.60	
A1	2.45	2.50	2.55	
A2	1.95	2.00	2.05	
b	0.65	0.75	0.85	
b1	1.07	1.27	1.47	
C	0.40	0.50	0.60	
C1	2.70	2.80	2.90	
D	9.90	10.00	10.10	
E	28.00	-	28.60	
E1	15.50	15.60	15.70	
E2	12.30	12.40	12.50	
E3	9.15	9.20	9.25	
F	3.30	3.40	3.50	
G	3.10	3.20	3.30	
e	2.54 BSC			
L	12.40	-	13.00	
L1	3.46 BSC			