

SWITCHING REGULATOR APPLICATIONS

Features

- High Voltage: $BV_{DSS}=500V(\text{Min.})$
- Low C_{RSS} : $C_{RSS}=25pF(\text{Typ.})$
- Low gate charge : $Q_g=45nc(\text{Typ.})$
- Low $R_{DS(on)}$: $R_{DS(on)}=0.48\Omega(\text{Max.})$

上海元佐电子有限公司
YOZO ELECTRONIC CO., LTD
WWW.YOZO.HK
021-54953990
021-54950919

Ordering Information

Type NO.	Marking	Package Code
STK1250F	STK1250	TO-220F-3L

Outline Dimensions

unit : mm

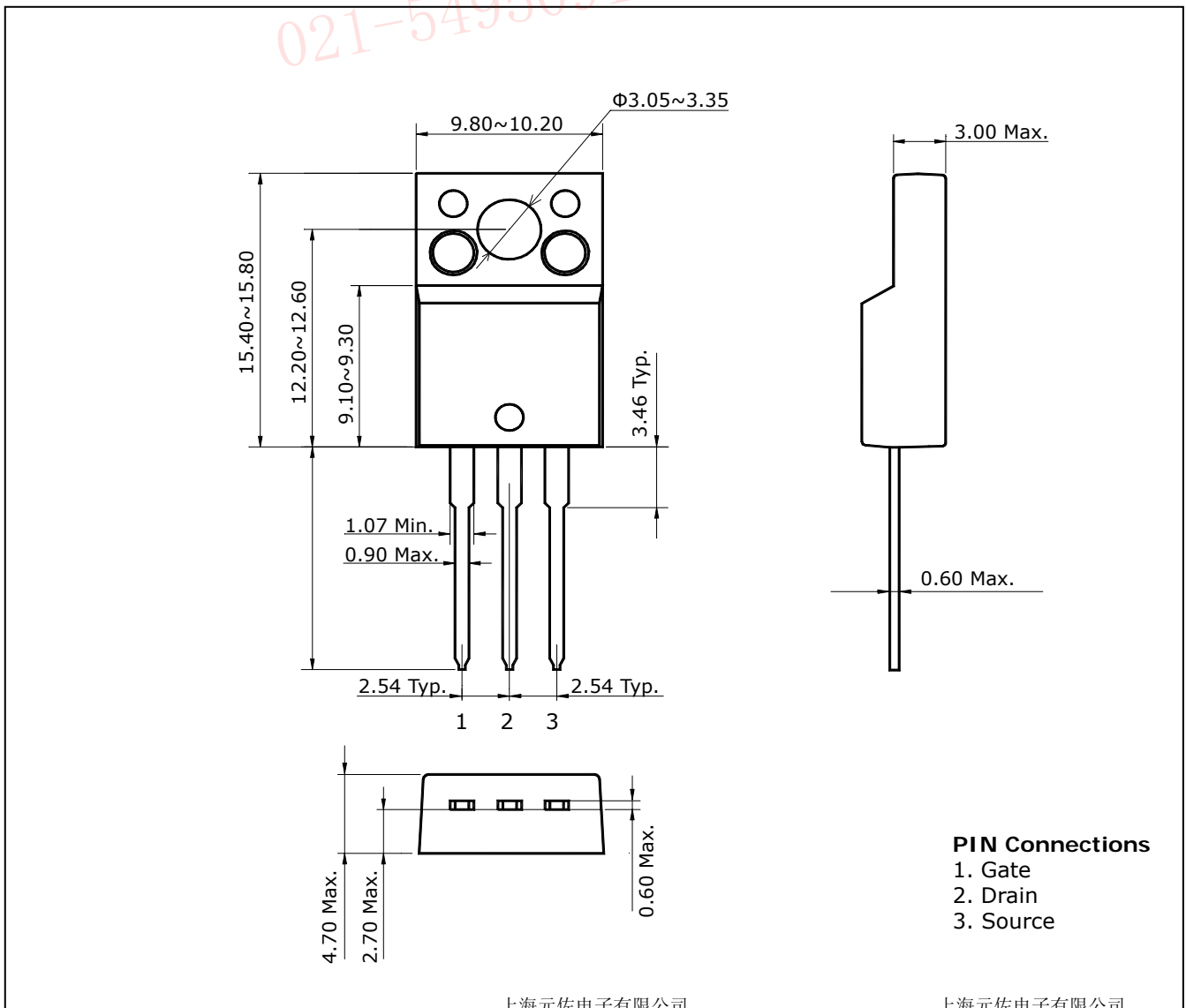

Absolute maximum ratings

(Tc=25°C)

Characteristic	Symbol	Rating	Unit
Drain-source voltage	V_{DSS}	500	V
Gate-source voltage	V_{GSS}	±30	V
Drain current (DC)	I_D	(Tc=25°C)	12
		(Tc=100°C)	6.5
Drain current (Pulsed) *	I_{DM}	48	A
Drain power dissipation	P_D	43	W
Avalanche current (Single) ②	I_{AS}	12	A
Single pulsed avalanche energy ②	E_{AS}	600	mJ
Avalanche current (Repetitive) ①	I_{AR}	12	A
Repetitive avalanche energy ①	E_{AR}	17	mJ
Junction temperature	T_J	150	°C
Storage temperature range	T_{stg}	-55~150	

* Limited by maximum junction temperature

Characteristic		Symbol	Typ.	Max	Unit
Thermal resistance	Junction-case	$R_{th(J-C)}$	-	2.90	°C/W
	Junction-ambient	$R_{th(J-a)}$	-	62.5	

Electrical Characteristics

(Tc=25°C)

Characteristic	Symbol	Test Condition	Min.	Typ.	Max.	Unit	
Drain-source breakdown voltage	BV_{DSS}	$I_D=250\mu A, V_{GS}=0$	500	-	-	V	
Gate threshold voltage	$V_{GS(th)}$	$I_D=250\mu A, V_{DS}=V_{GS}$	2.0	-	4.0	V	
Drain-source cut-off current	I_{DSS}	$V_{DS}=500V, V_{GS}=0V$	-	-	1	μA	
Gate leakage current	I_{GSS}	$V_{DS}=0V, V_{GS}=\pm 30V$	-	-	± 100	nA	
Drain-source on-resistance ④	$R_{DS(ON)}$	$V_{GS}=10V, I_D=6A$	-	0.40	0.48	Ω	
Forward transfer conductance ④	g_{fs}	$V_{DS}=50V, I_D=6A$	-	12	-	S	
Input capacitance	C_{iss}	$V_{GS}=0V, V_{DS}=25V$ $f=1MHz$	-	1380	2010	pF	
Output capacitance	C_{oss}		-	179	240		
Reverse transfer capacitance	C_{rss}		-	25	-		
Turn-on delay time	$t_{d(on)}$	$V_{DD}=250V, I_D=12A$ $R_G=25\Omega$	-	25	-	ns	
Rise time	t_r		-	100	-		
Turn-off delay time	$t_{d(off)}$		③④	-	130		-
Fall time	t_f		-	100	-		
Total gate charge	Q_g	$V_{DS}=400V, V_{GS}=10V$ $I_D=12A$	-	45	60	nC	
Gate-source charge	Q_{gs}		③④	-	8.0		-
Gate-drain charge	Q_{gd}		-	17.5	-		

Source-Drain Diode Ratings and Characteristics

(Tc=25°C)

Characteristic	Symbol	Test Condition	Min	Typ	Max	Unit
Source current (DC)	I_S	Integral reverse diode in the MOSFET	-	-	12	A
Source current (Pulsed) ①	I_{SM}		-	-	48	
Forward voltage ④	V_{SD}	$V_{GS}=0V, I_S=12A$	-	-	1.4	V
Reverse recovery time	t_{rr}	$I_S=12A, V_{GS}=0,$ $di_S/dt=100A/\mu s$	-	400	-	ns
Reverse recovery charge	Q_{rr}		-	4.8	-	μC

Note ;

- ① Repetitive Rating : Pulse Width Limited by Maximum Junction Temperature
- ② $L=7.5mH, I_{AS}=12A, V_{DD}=50V, R_G=25\Omega$
- ③ Pulse Test : Pulse Width < 300us, Duty cycle ≤ 2%
- ④ Essentially independent of operating temperature

Electrical Characteristic Curves

Fig. 1 $I_D - V_{DS}$

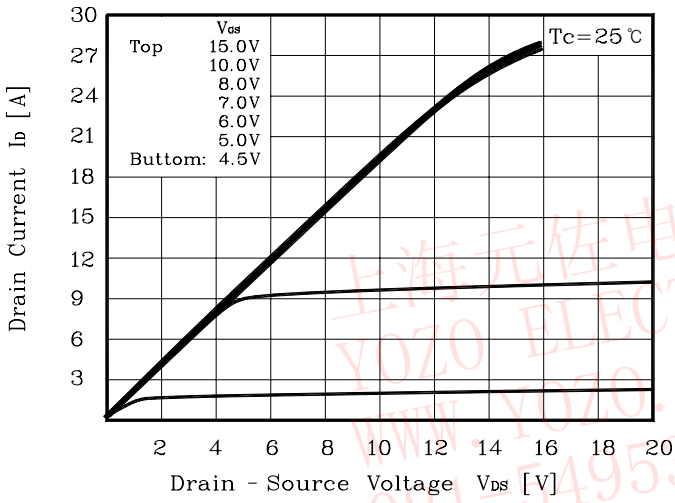

Fig. 2 $I_D - V_{GS}$

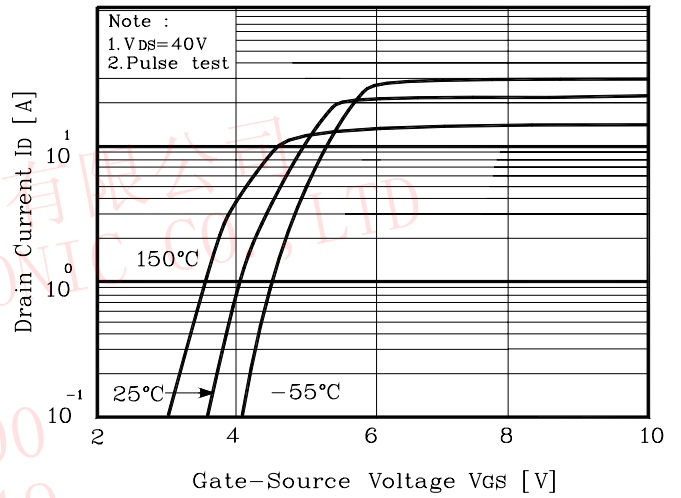

Fig. 3 $R_{DS(on)} - I_D$

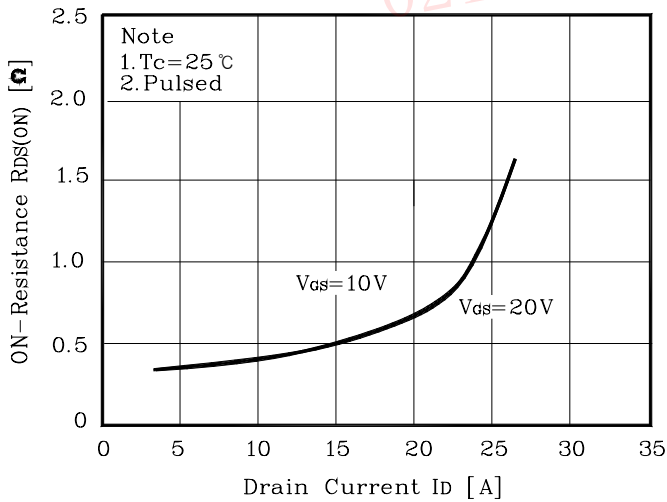

Fig. 4 $I_S - V_{SD}$

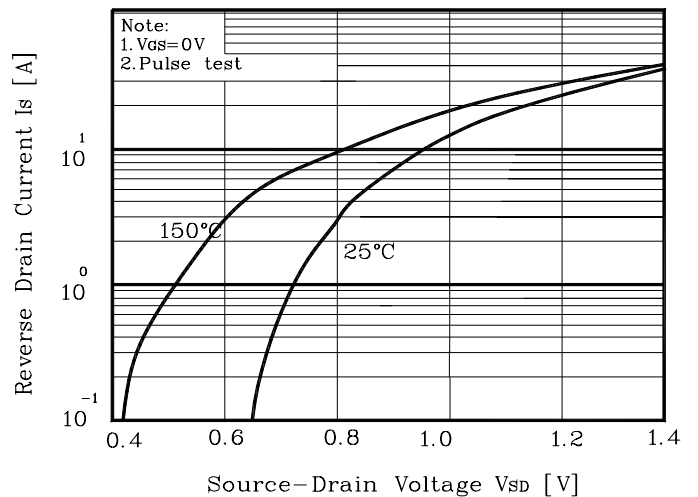

Fig. 5 Capacitance - V_{DS}

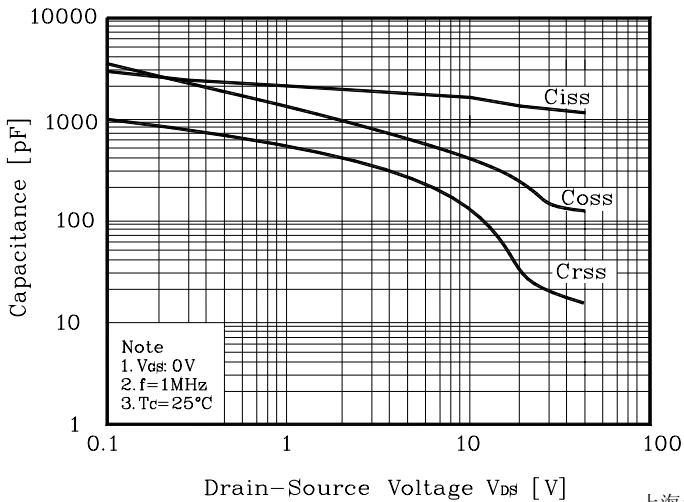

Fig. 6 $V_{GS} - Q_G$

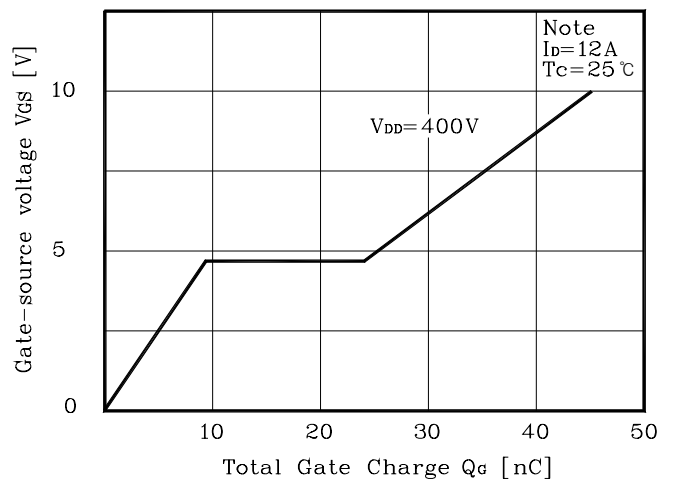

Fig. 7 $V_{DSS} - T_J$

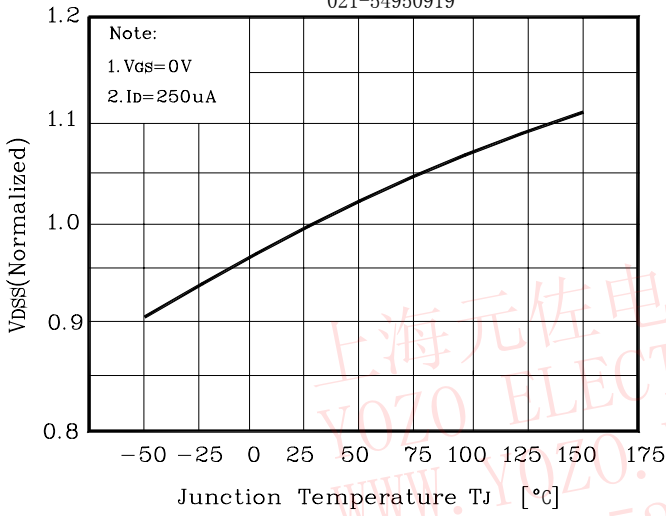

Fig.8 $R_{DS(on)} - T_J$

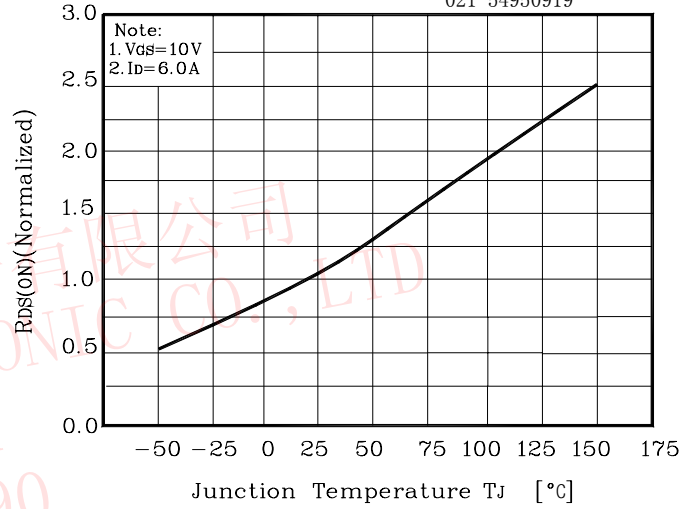

Fig. 9 $I_D - T_C$

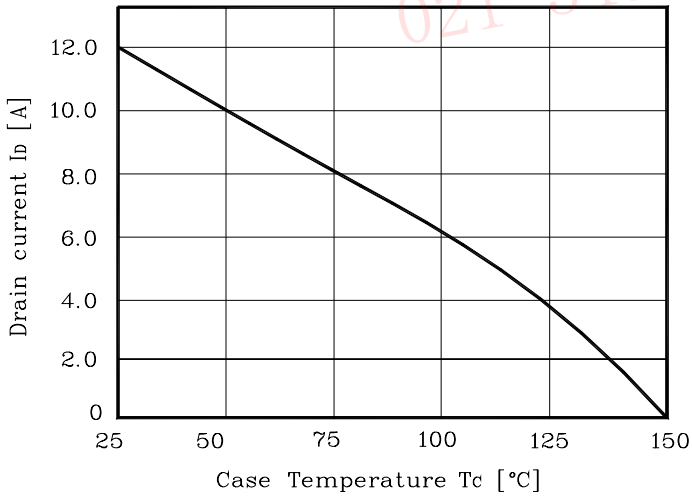

Fig. 10 Safe Operating Area

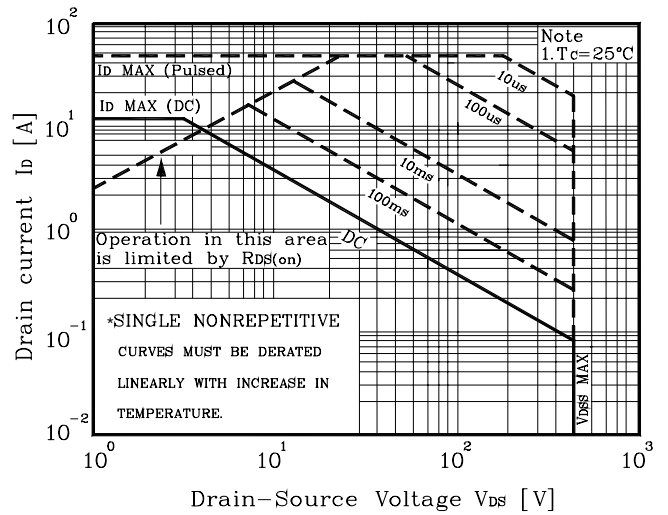

Fig. 10 Gate Charge Test Circuit & Waveform

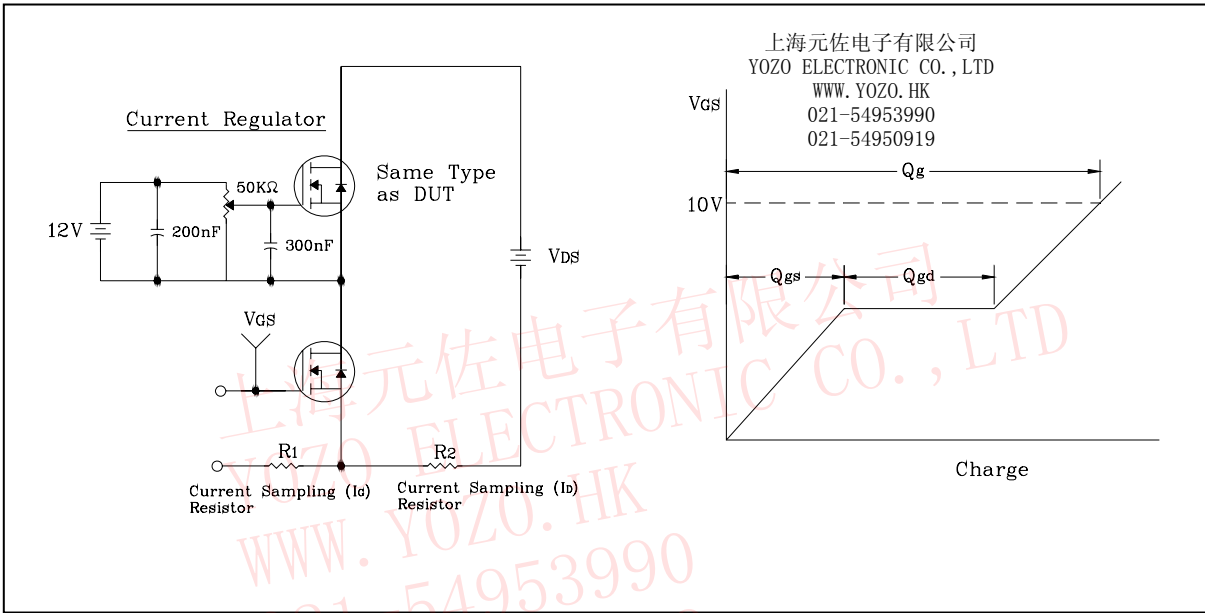

Fig. 11 Resistive Switching Test Circuit & Waveform

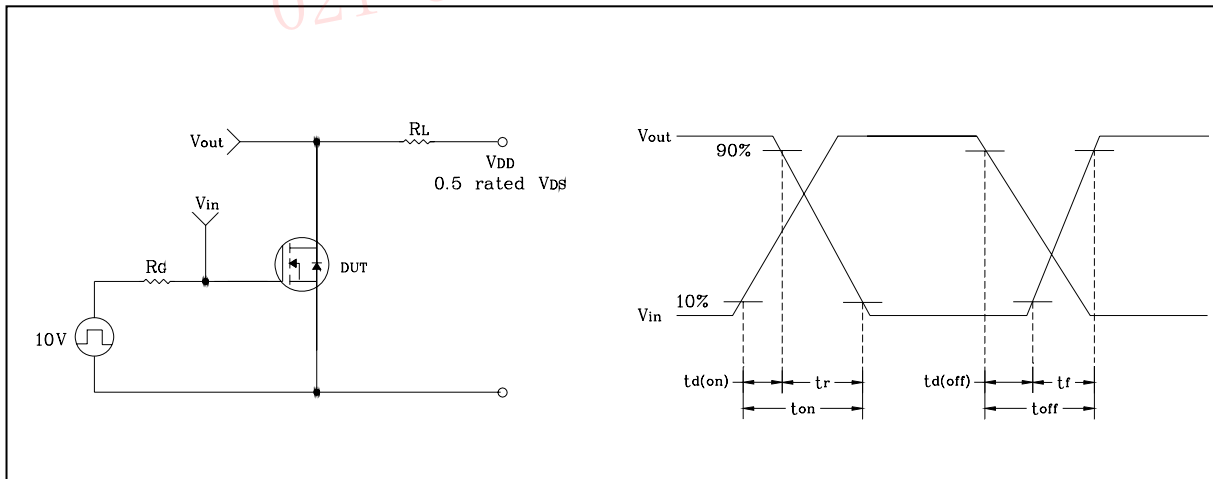

Fig. 12 EAS Test Circuit & Waveform

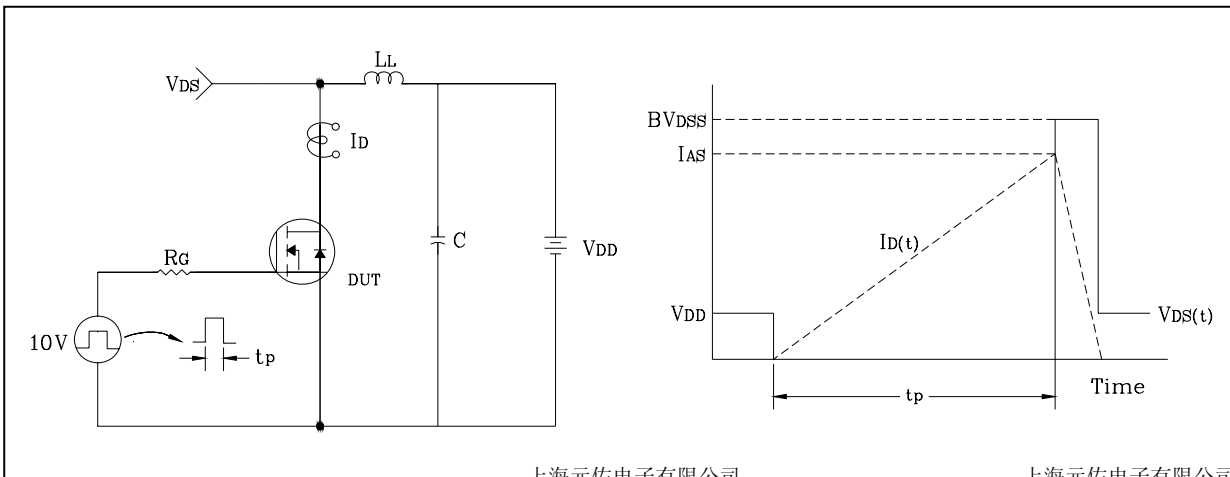

Fig. 13 Diode Reverse Recovery Time Test Circuit & Waveform

