

SWITCHING REGULATOR APPLICATIONS

 上海元佐电子
 WWW.YOZO.HK
 021-54953990
 021-54950919

Features

- High Voltage : $BV_{DSS}=500V(\text{Min.})$
- Low C_{RSS} : $C_{RSS}=33pF(\text{Typ.})$
- Low gate charge : $Q_g=16nC(\text{Typ.})$
- Low $R_{DS(on)}$: $R_{DS(on)}=1.5\Omega(\text{Max.})$

Ordering Information

Type No.	Marking	Package Code
SMK830F	SMK830	TO-220F-3L

PIN Connection

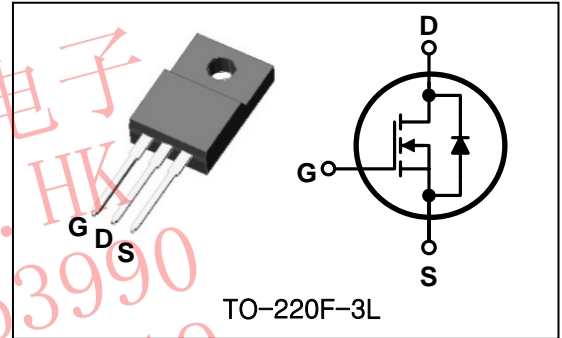

Marking Diagram

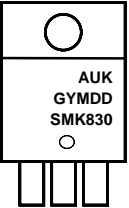
	Column 1 : Manufacturer Column 2 : Production Information e.g.) GYMDD -. G : Factory management code -. YMDD : Date Code (year, month, date) Column 3 : Device Code
--	--

Absolute maximum ratings ($T_C=25^\circ\text{C}$ unless otherwise noted)

Characteristic	Symbol	Rating	Unit	
Drain-source voltage	V_{DSS}	500	V	
Gate-source voltage	V_{GSS}	± 30	V	
Drain current (DC) *	I_D	$T_C=25^\circ\text{C}$	4.5	A
		$T_C=100^\circ\text{C}$	2.8	A
Drain current (Pulsed) *	I_{DM}	18	A	
Power dissipation	P_D	30	W	
Avalanche current (Single) ②	I_{AS}	4.5	A	
Single pulsed avalanche energy ②	E_{AS}	472	mJ	
Avalanche current (Repetitive) ①	I_{AR}	4.5	A	
Repetitive avalanche energy ①	E_{AR}	5.0	mJ	
Junction temperature	T_J	150	$^\circ\text{C}$	
Storage temperature range	T_{stg}	-55~150	$^\circ\text{C}$	

* Limited by maximum junction temperature

Characteristic	Symbol	Typ.	Max.	Unit
Thermal resistance	Junction-case	-	4.16	$^\circ\text{C}/\text{W}$
	Junction-ambient	-	62.5	

Electrical Characteristics (T_C=25°C unless otherwise noted)

Characteristic	Symbol	Test Condition	Min.	Typ.	Max.	Unit
Drain-source breakdown voltage	V _{(BR)DSS}	I _D =250uA, V _{GS} =0V	500	-	-	V
Gate threshold voltage	V _{GS(th)}	I _D =250uA, V _{DS} =V _{GS}	2.0	-	4.0	V
Drain-source cut-off current	I _{DSS}	V _{DS} =500V, V _{GS} =0V	-	-	1	uA
Gate leakage current	I _{GSS}	V _{DS} =0V, V _{GS} =±30V	-	-	±100	nA
Drain-source on-resistance ④	R _{DS(on)}	V _{GS} =10V, I _D =2.25A	-	1.2	1.5	Ω
Forward transfer conductance ④	g _{fs}	V _{DS} =10V, I _D =2.25A	-	5.2	-	S
Input capacitance	C _{iss}	V _{GS} =0V, V _{DS} =25V f=1 MHz	-	745	930	pF
Output capacitance	C _{oss}		-	82	102	
Reverse transfer capacitance	C _{rss}		-	33	42	
Turn-on delay time	t _{d(on)}	V _{DD} =250V, I _D =4.5A R _G =25Ω	-	12	-	ns
Rise time	t _r		-	46	-	
Turn-off delay time	t _{d(off)}		-	50	-	
Fall time	t _f		-	48	-	
Total gate charge	Q _g	V _{DS} =400V, V _{GS} =10V I _D =4.5A	-	16	20	nC
Gate-source charge	Q _{gs}		-	5.5	-	
Gate-drain charge	Q _{gd}		-	4.0	-	

Source-Drain Diode Ratings and Characteristics (T_C=25°C unless otherwise noted)

Characteristic	Symbol	Test Condition	Min.	Typ.	Max.	Unit
Source current (DC)	I _S	Integral reverse diode in the MOSFET	-	-	4.5	A
Source current (Pulsed) ①	I _{SM}		-	-	18	
Forward voltage ④	V _{SD}	V _{GS} =0V, I _S =4.5A	-	-	1.4	V
Reverse recovery time	t _{rr}	I _S =4.5A, V _{GS} =0V	-	263	-	ns
Reverse recovery charge	Q _{rr}	dI _F /dt=100A/μs	-	1.9	-	μC

Note ;

- ① Repetitive rating : Pulse width limited by maximum junction temperature
- ② L=42mH, I_{AS}=4.5A, V_{DD}=50V, R_G=25Ω, Starting T_J=25°C
- ③ Pulse Test : Pulse width≤300us, Duty cycle≤2%
- ④ Essentially independent of operating temperature

Electrical Characteristic Curves

Fig. 1 $I_D - V_{DS}$

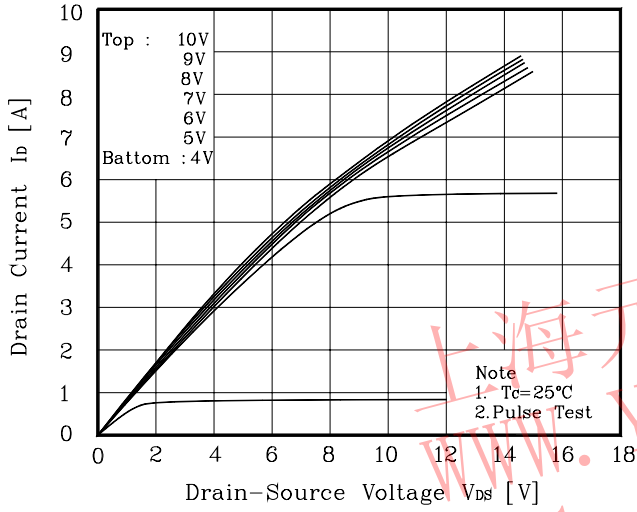

Fig. 2 $I_D - V_{GS}$

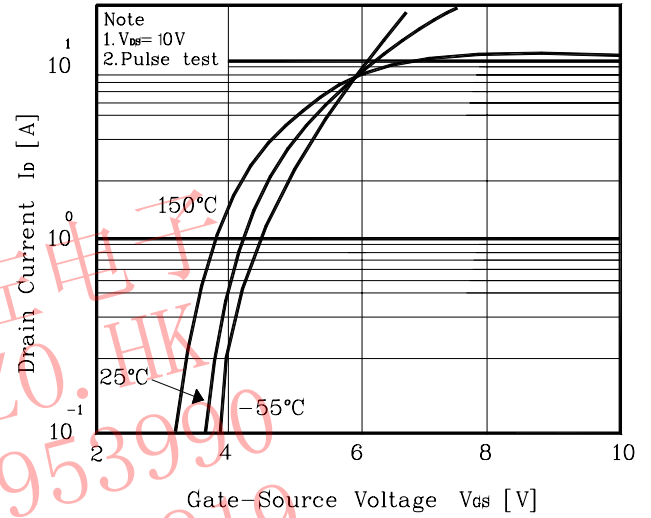

Fig. 3 $R_{DS(on)} - I_D$

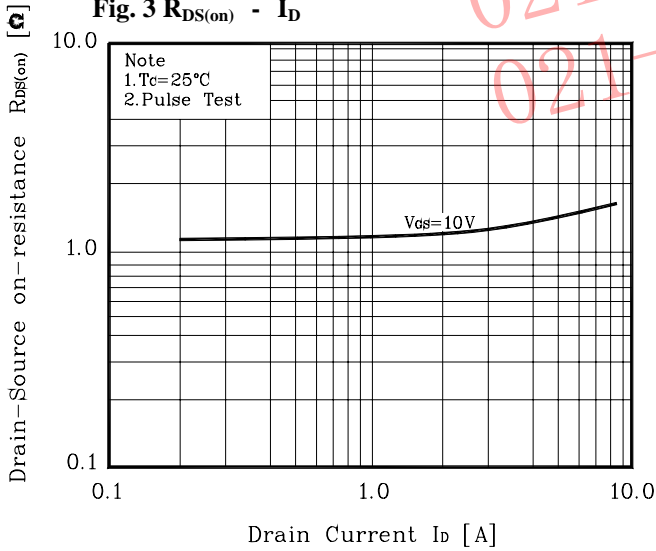

Fig. 4 $I_S - V_{SD}$

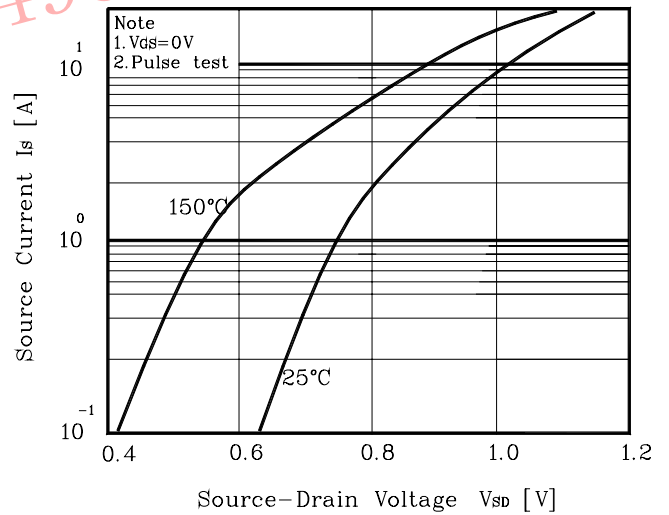

Fig. 5 Capacitance - V_{DS}

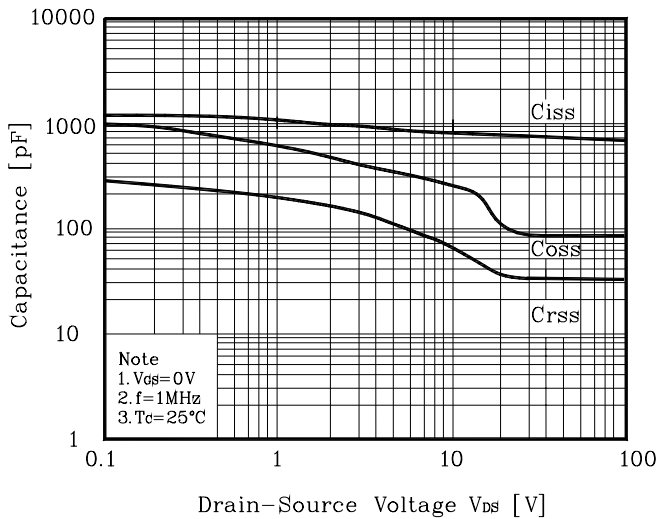

Fig. 6 $V_{GS} - Q_G$

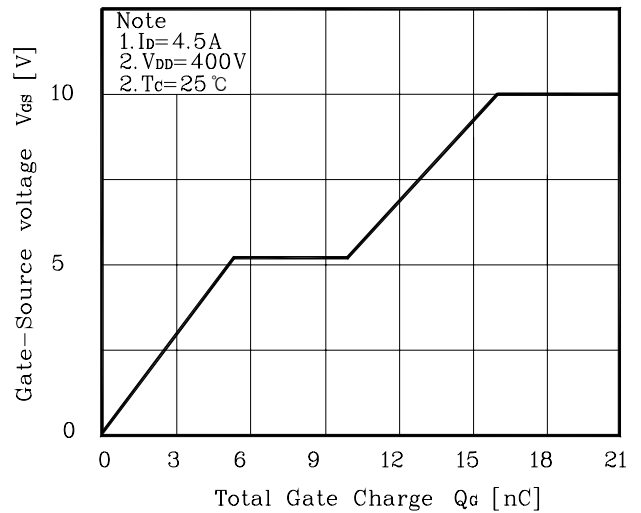

Fig. 7 $V_{(BR)DSS} - T_J$

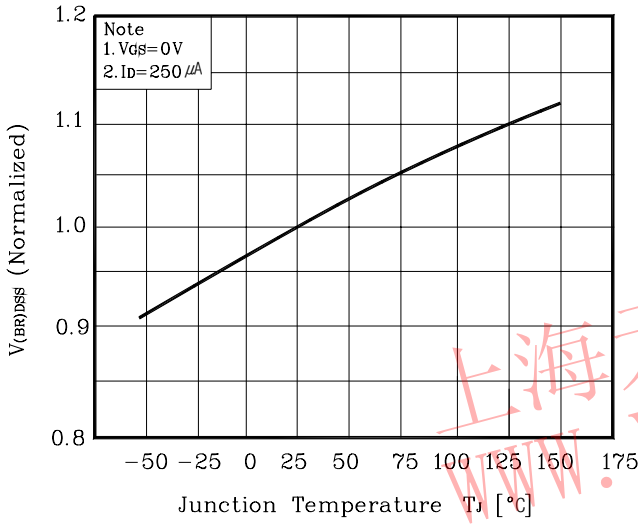

Fig. 8 $R_{DS(on)} - T_J$

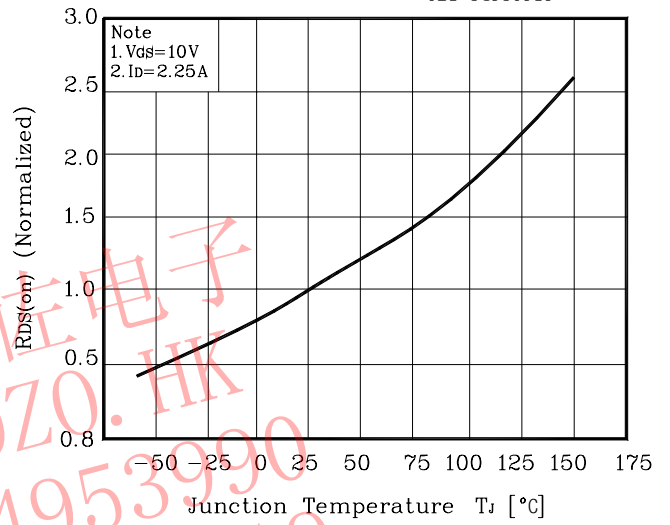

Fig. 9 $I_D - T_C$

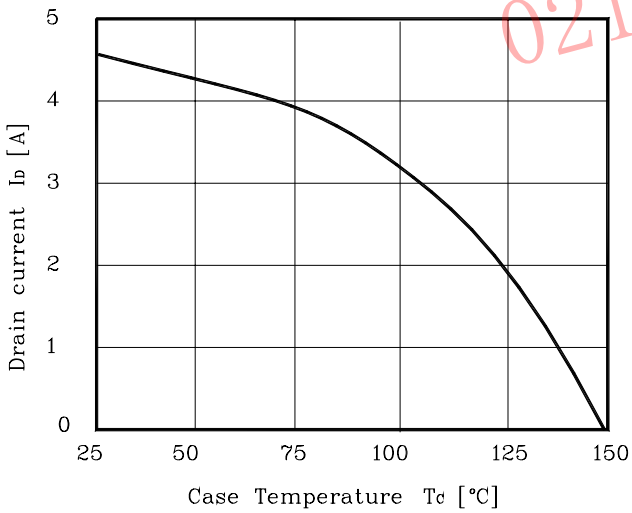

Fig. 10 Safe Operating Area

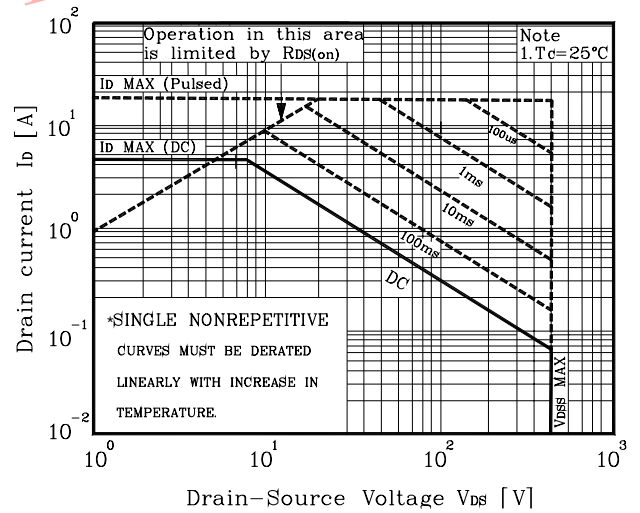

Fig. 11 Gate Charge Test Circuit & Waveform

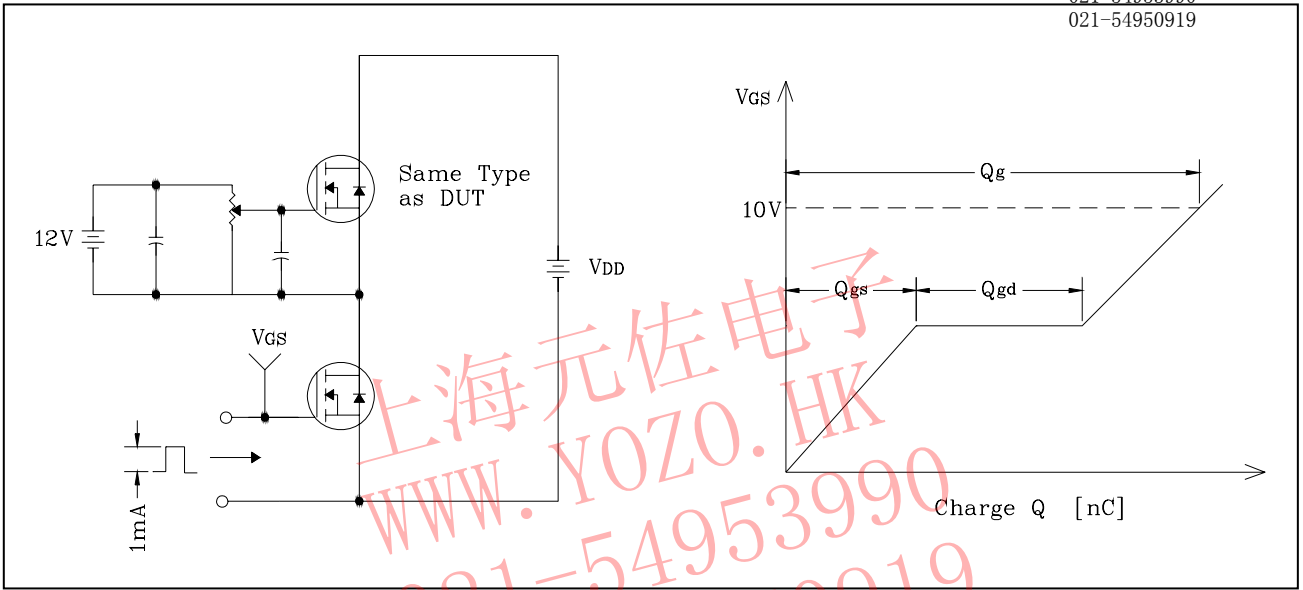

Fig. 12 Switching Time Test Circuit & Waveform

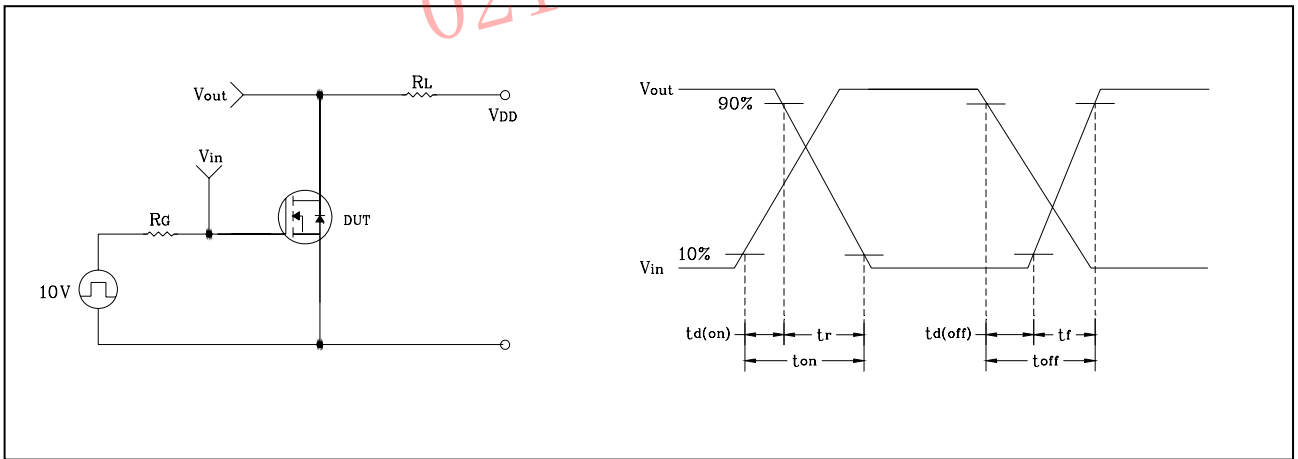

Fig. 13 EAS Test Circuit & Waveform

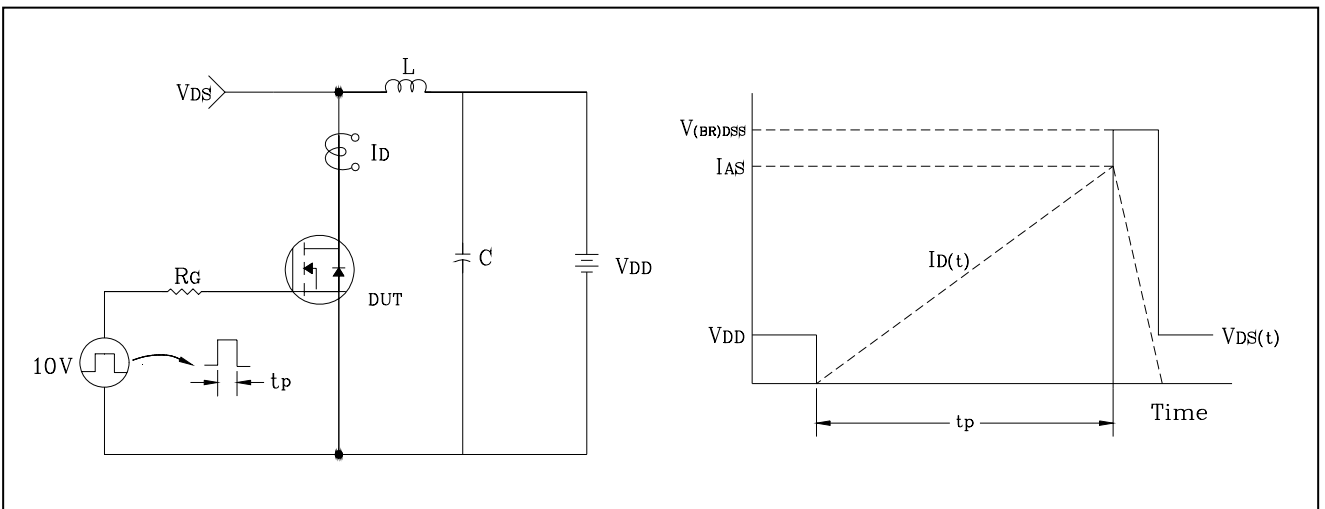
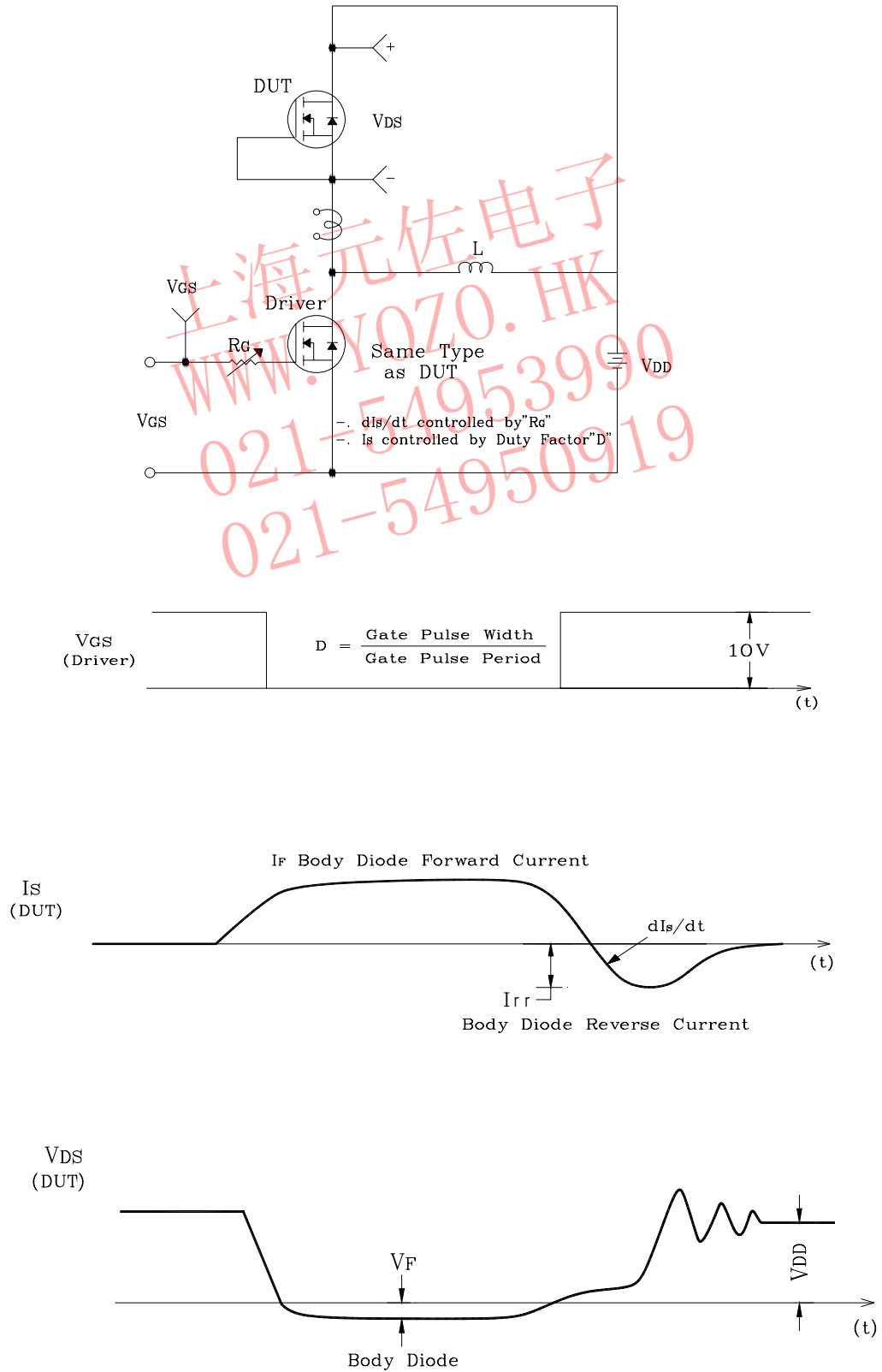
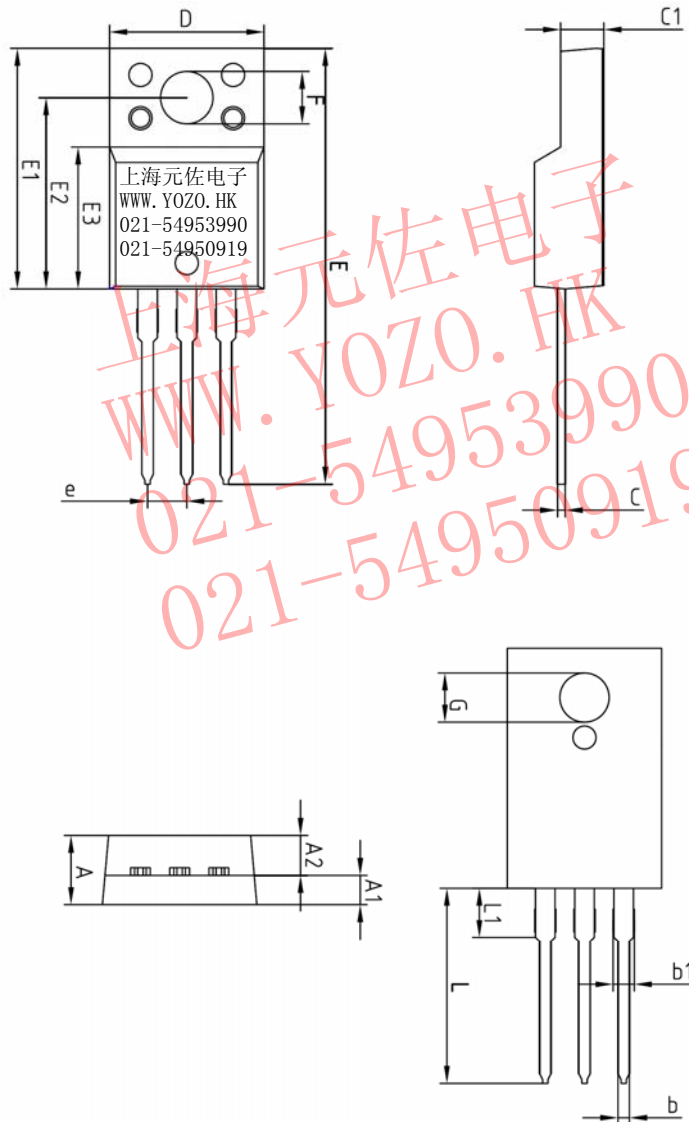

Fig. 14 Peak Diode Recovery dv/dt Test Circuit & Waveform



Outline Dimension



SYMBOL	MILLIMETERS			NOTE
	MINIMUM	NOMINAL	MAXIMUM	
A	-	-	4.60	
A1	2.45	2.50	2.55	
A2	1.95	2.00	2.05	
b	0.65	0.75	0.85	
b1	1.07	1.27	1.47	
C	0.40	0.50	0.60	
C1	2.70	2.80	2.90	
D	9.90	10.00	10.10	
E	28.00	-	28.60	
E1	15.50	15.60	15.70	
E2	12.30	12.40	12.50	
E3	9.15	9.20	9.25	
F	3.30	3.40	3.50	
G	3.10	3.20	3.30	
e	2.54 BSC			
L	12.40	-	13.00	
L1	3.46 BSC			