

SWITCHING REGULATOR APPLICATIONS

Features

- High Voltage: $BV_{DSS}=600V(\text{Min.})$
- Low C_{RSS} : $C_{RSS}=9.8pF(\text{Typ.})$
- Low gate charge : $Q_g=12nC(\text{Typ.})$
- Low $R_{DS(on)}$: $R_{DS(on)}=2.5\Omega(\text{Max.})$

上海元佐电子
WWW.YOZO.HK
021-54953990
021-54950919

PIN Connection

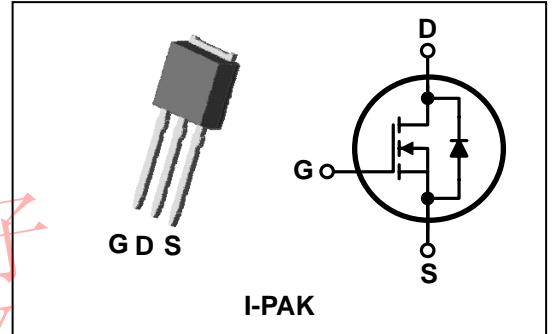

Ordering Information

Type No.	Marking	Package Code
SMK0460I	SMK0460	I-PAK

Marking Diagram

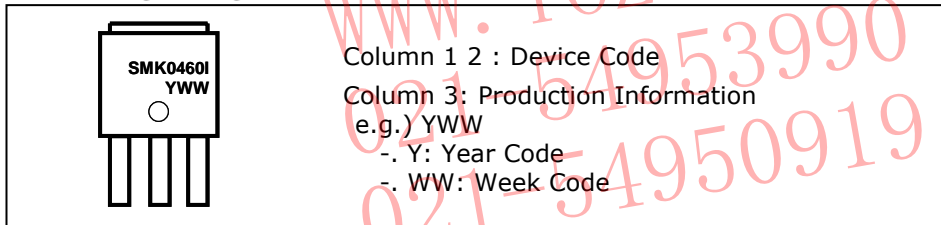

Absolute maximum ratings ($T_C=25^\circ\text{C}$ unless otherwise noted)

Characteristic	Symbol	Rating	Unit
Drain-source voltage	V_{DSS}	600	V
Gate-source voltage	V_{GSS}	± 30	V
Drain current (DC)	I_D	($T_C=25^\circ\text{C}$)	4
		($T_C=100^\circ\text{C}$)	2.53
Drain current (Pulsed) *	I_{DM}	16	A
Drain Power dissipation	P_D	48	W
Avalanche current (Single) ②	I_{AS}	4	A
Single pulsed avalanche energy ②	E_{AS}	225	mJ
Avalanche current (Repetitive) ①	I_{AR}	4	A
Repetitive avalanche energy ①	E_{AR}	10	mJ
Junction temperature	T_J	150	$^\circ\text{C}$
Storage temperature range	T_{stg}	-55~150	

* Limited by maximum junction temperature

Characteristic	Symbol	Typ.	Max	Unit	
Thermal resistance	Junction-case	$R_{th(J-C)}$	-	2.6	$^\circ\text{C}/\text{W}$
	Junction-ambient	$R_{th(J-a)}$	-	62.5	

Electrical Characteristics ($T_C=25^\circ\text{C}$ unless otherwise noted)

Characteristic	Symbol	Test Condition	Min.	Typ.	Max.	Unit	
Drain-source breakdown voltage	BV_{DSS}	$I_D=250\mu\text{A}, V_{GS}=0$	600	-	-	V	
Gate-threshold voltage	$V_{GS(th)}$	$I_D=250\mu\text{A}, V_{DS}=V_{GS}$	2.0	-	4.0	V	
Drain-source leakage current	I_{DSS}	$V_{DS}=600\text{V}, V_{GS}=0\text{V}$	-	-	1	μA	
Gate-source leakage	I_{GSS}	$V_{DS}=0\text{V}, V_{GS}=\pm 30\text{V}$	-	-	± 100	nA	
Drain-Source on-resistance ④	$R_{DS(ON)}$	$V_{GS}=10\text{V}, I_D=2.0\text{A}$	-	2.1	2.5	Ω	
Forward transfer admittance ④	g_{fs}	$V_{DS}=10\text{V}, I_D=2.0\text{A}$	-	4.0	-	S	
Input capacitance	C_{iss}	$V_{GS}=0\text{V}, V_{DS}=25\text{V}, f=1\text{MHz}$	-	670	848	pF	
Output capacitance	C_{oss}		-	57	71		
Reverse transfer capacitance	C_{rss}		-	9.8	12.2		
Turn-on delay time	$t_{d(on)}$	$V_{DD}=300\text{V}, I_D=4\text{A}$ $R_G=25\Omega$	-	10	-	ns	
Rise time	t_r		-	42	-		
Turn-off delay time	$t_{d(off)}$		③④	-	38		-
Fall time	t_f		-	46	-		
Total gate charge	Q_g	$V_{DS}=480\text{V}, V_{GS}=10\text{V}$ $I_D=4\text{A}$	-	12	15	nC	
Gate-source charge	Q_{gs}		-	4	-		
Gate-drain charge	Q_{gd}		③④	-	3		-

Source-Drain Diode Ratings and Characteristics ($T_C=25^\circ\text{C}$ unless otherwise noted)

Characteristic	Symbol	Test Condition	Min	Typ	Max	Unit
Continuous source current	I_S	Integral reverse diode in the MOSFET	-	-	4	A
Source current (Pulsed) ①	I_{SM}		-	-	16	
Forward voltage ④	V_{SD}	$V_{GS}=0\text{V}, I_S=4\text{A}$	-	-	1.4	V
Reverse recovery time	t_{rr}	$I_S=4\text{A}$ $di_s/dt=100\text{A}/\mu\text{s}$	-	300	-	ns
Reverse recovery charge	Q_{rr}		-	2.2	-	μC

Note ;

- ① Repetitive Rating : Pulse Width Limited by Maximum Junction Temperature
- ② $L=25.9\text{mH}, I_{AS}=4\text{A}, V_{DD}=50\text{V}, R_G=27\Omega$, Starting $T_J = 25^\circ\text{C}$
- ③ Pulse Test : Pulse Width < 300us, Duty cycle $\leq 2\%$
- ④ Essentially independent of operating temperature

Electrical Characteristic Curves

Fig. 1 $I_D - V_{DS}$

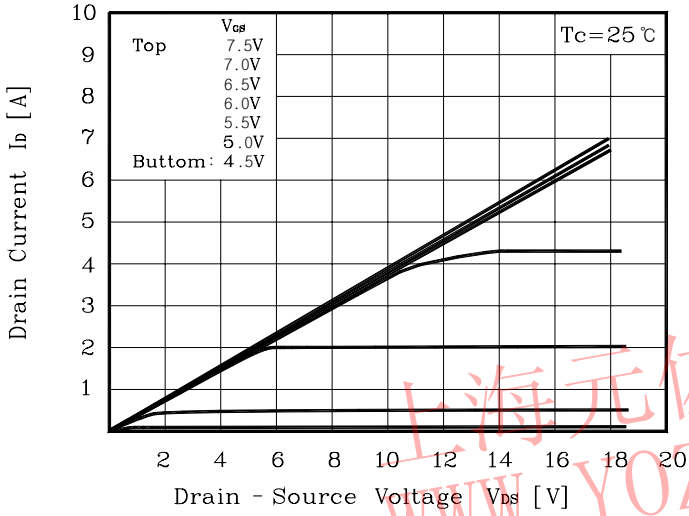

Fig. 2 $I_D - V_{GS}$

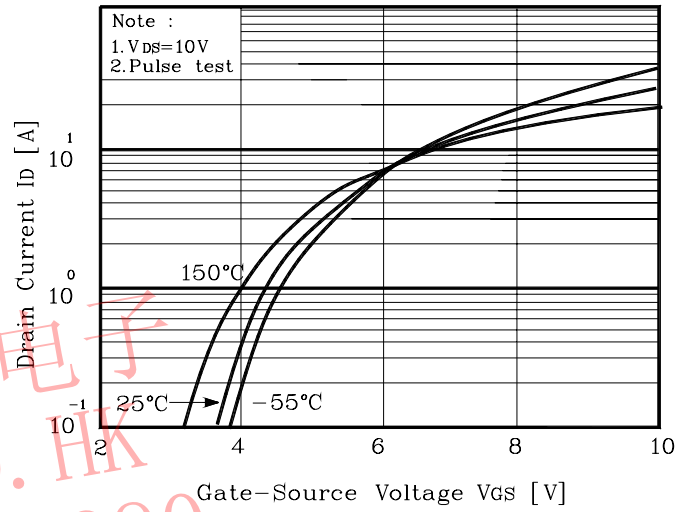

Fig. 3 $R_{DS(on)} - I_D$

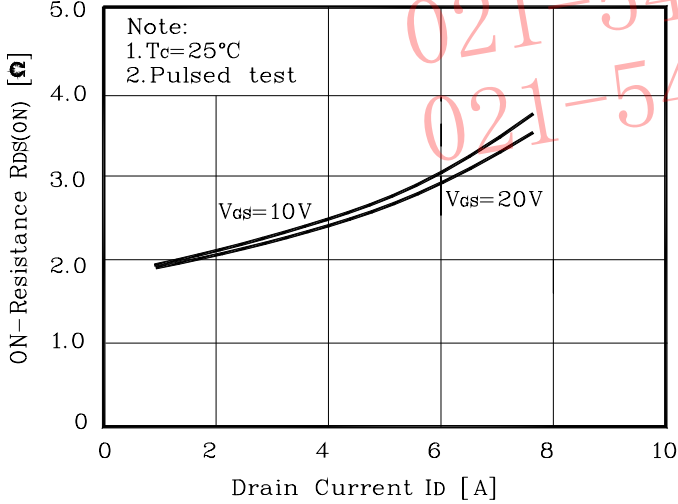

Fig. 4 $I_S - V_{SD}$

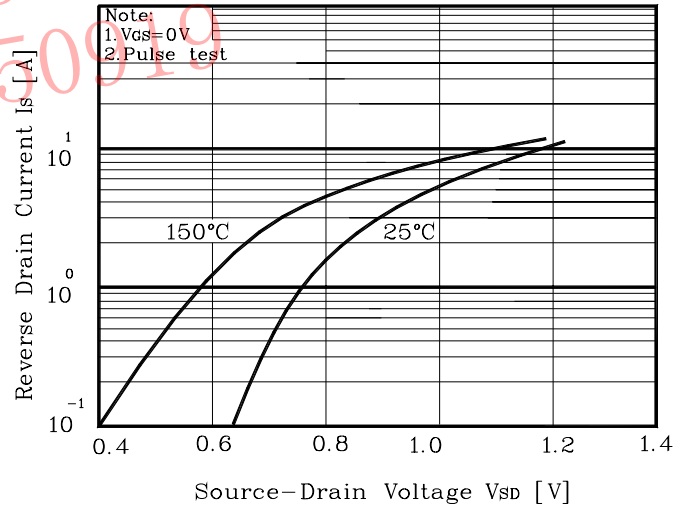

Fig. 5 Capacitance - V_{DS}

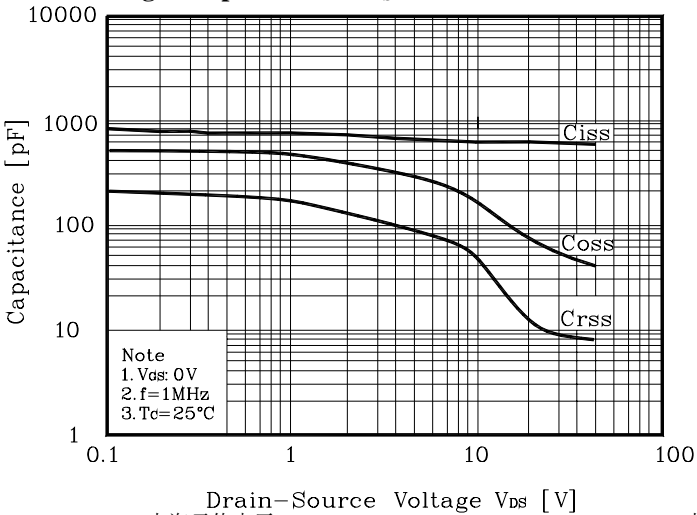
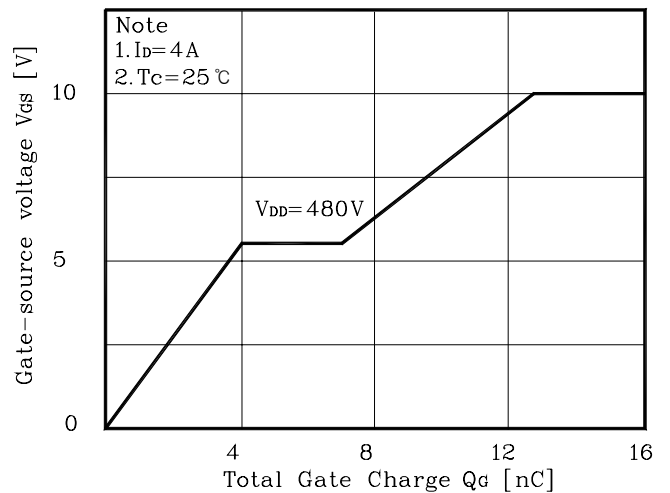

Fig. 6 $V_{GS} - Q_G$



Electrical Characteristic Curves

Fig. 7 $V_{DSS} - T_J$

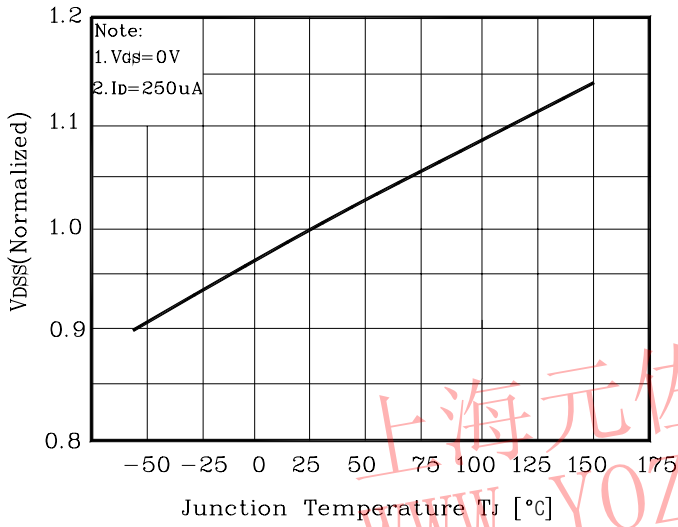

Fig. 8 $R_{DS(on)} - T_J$

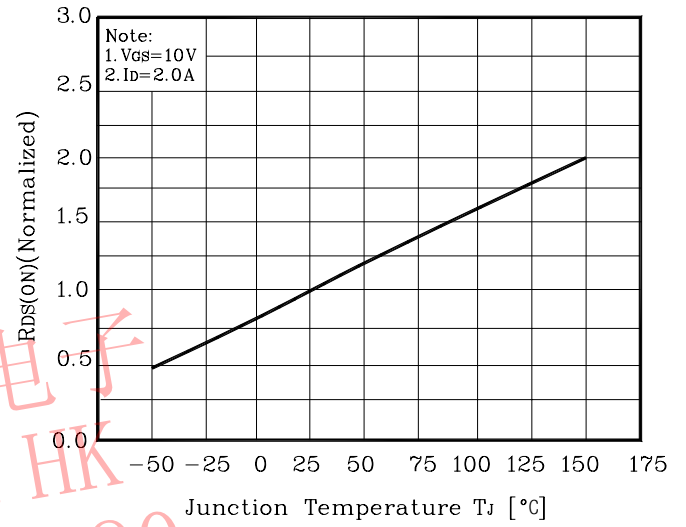

Fig. 9 $I_D - T_C$

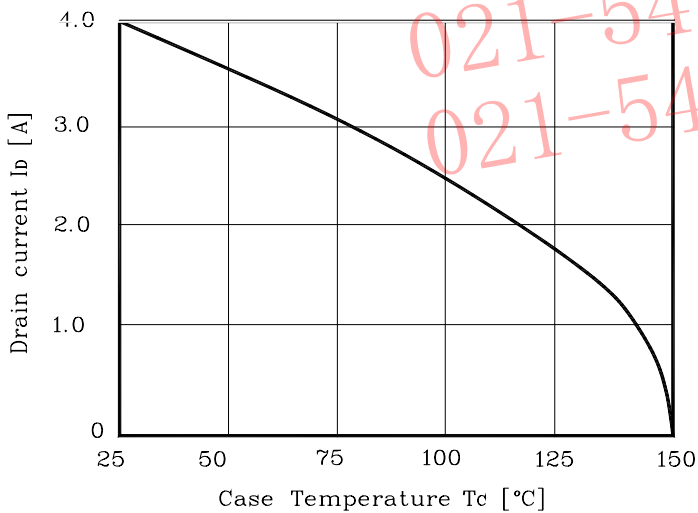

Fig. 10 Safe Operating Area

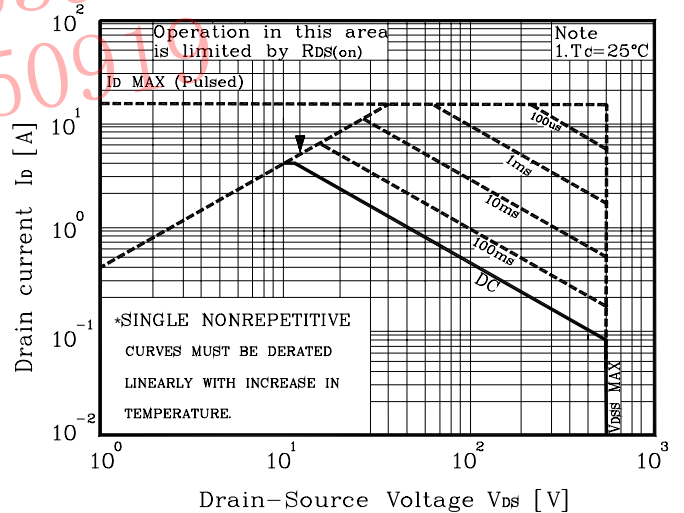

Fig. 11 Gate Charge Test Circuit & Waveform

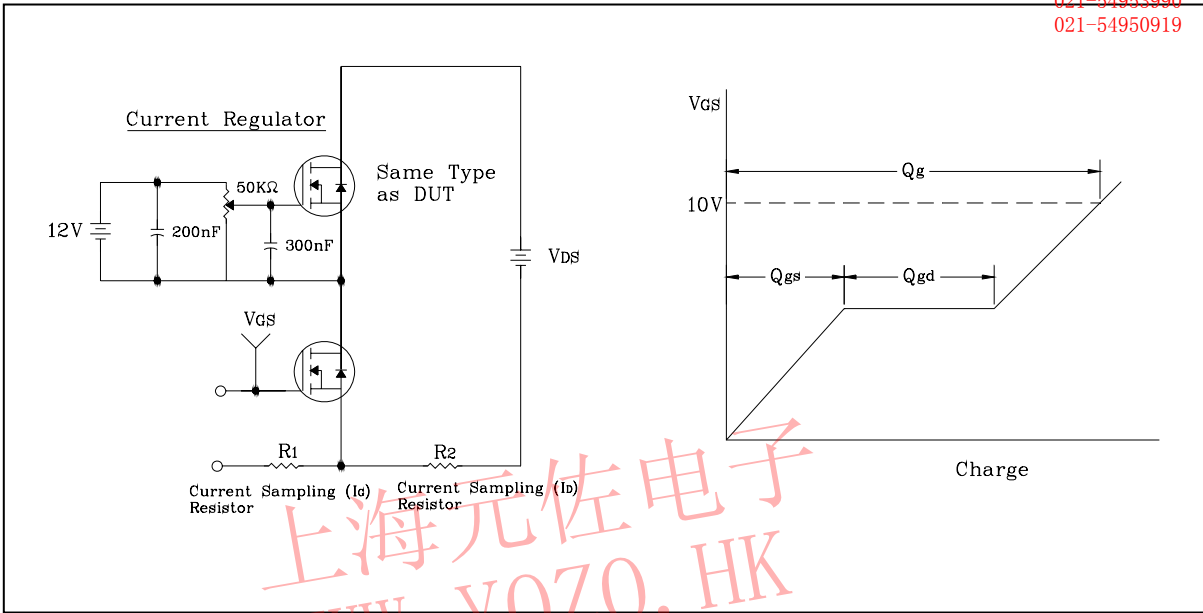

Fig. 12 Resistive Switching Test Circuit & Waveform

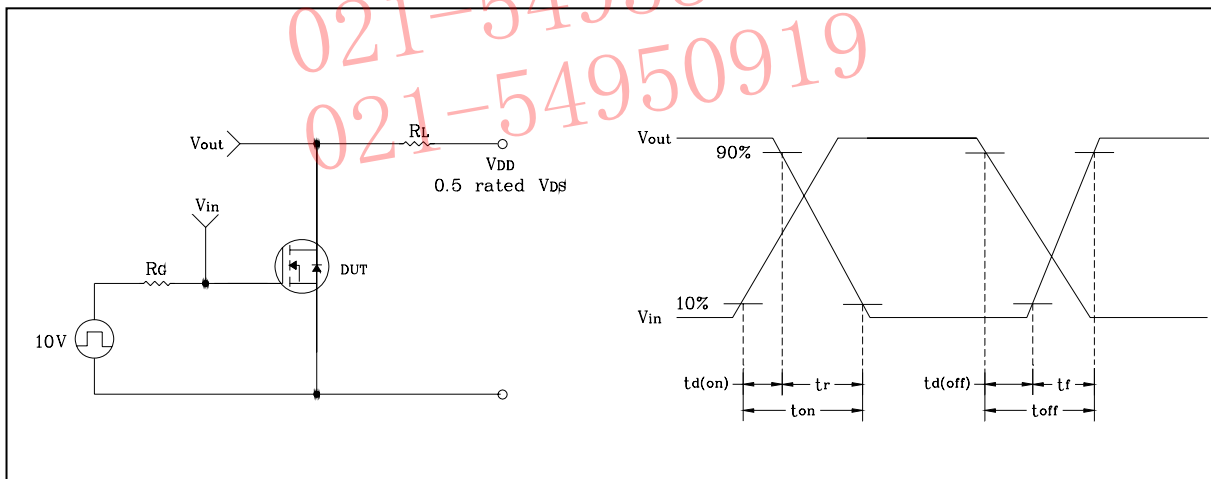

Fig. 13 E_{AS} Test Circuit & Waveform

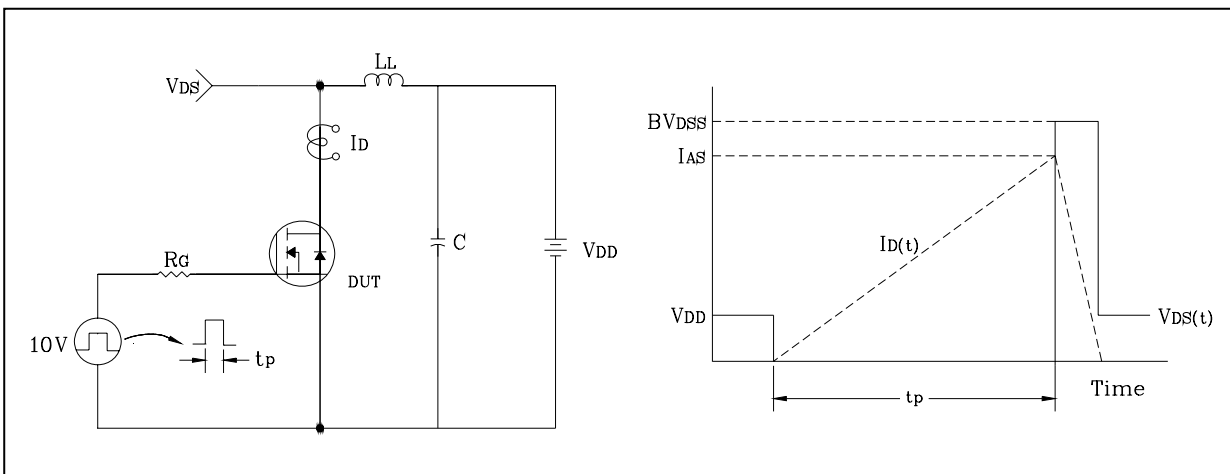
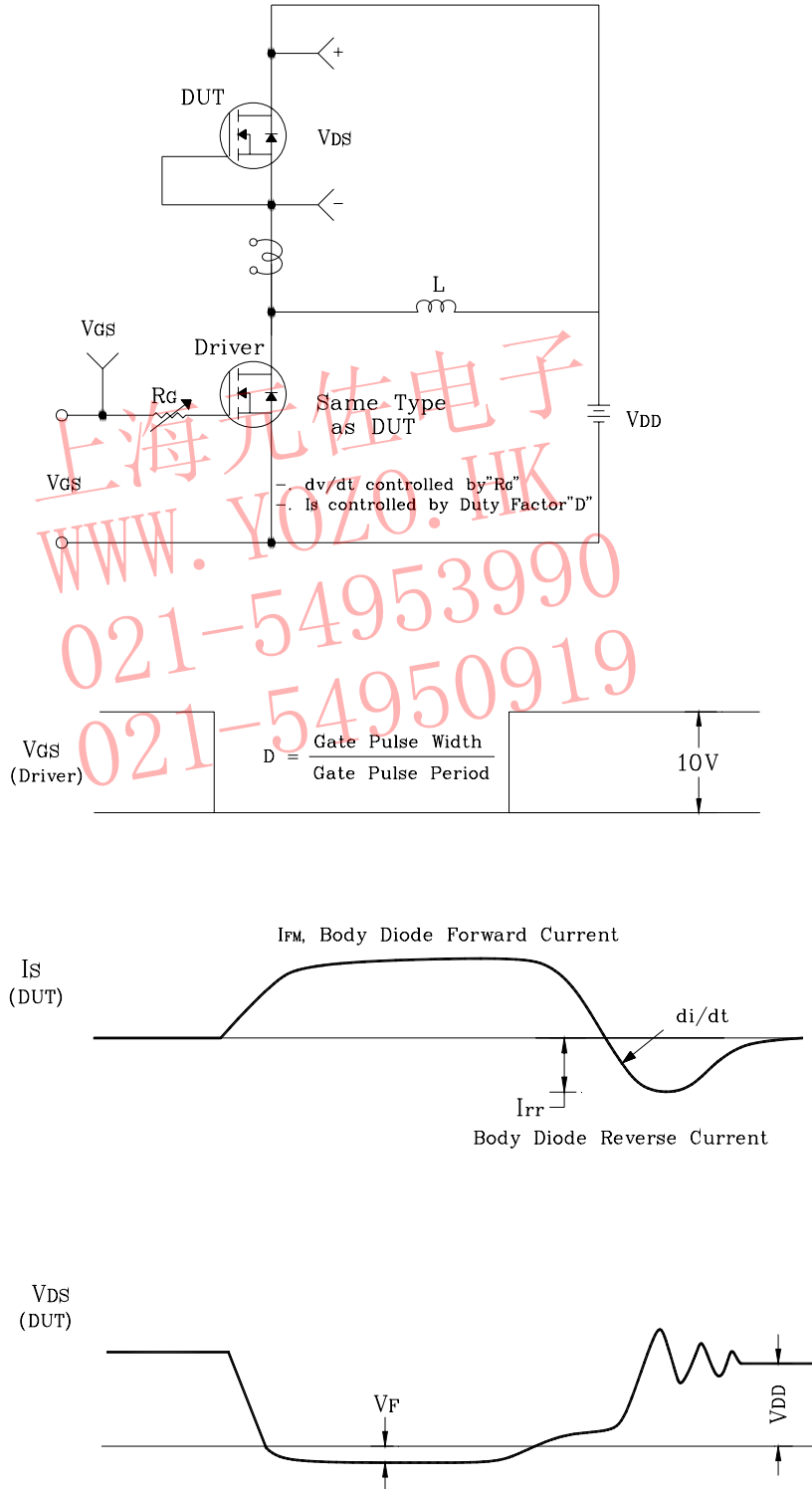
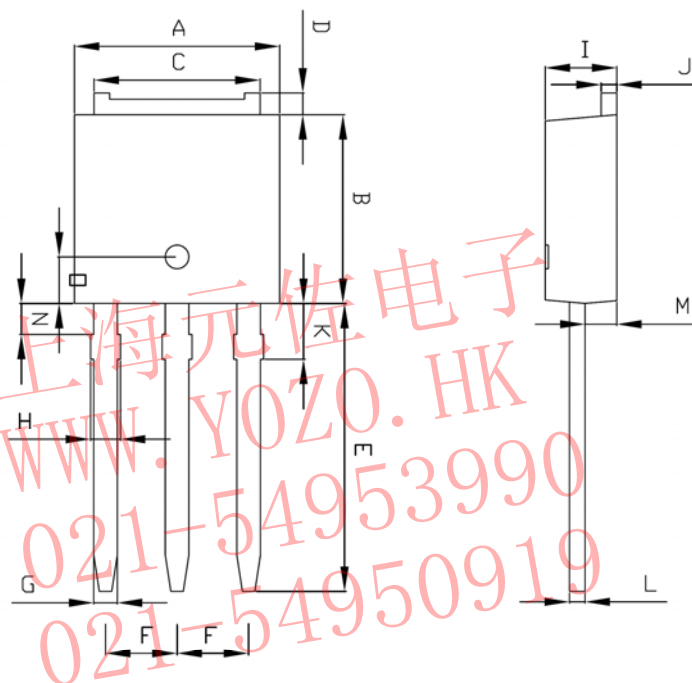

Fig. 14 Diode Reverse Recovery Time Test Circuit & Waveform



Outline Dimension



SYMBOL	MILLIMETERS			NOTE
	MINIMUM	NOMINAL	MAXIMUM	
A	6.40	6.60	6.80	
B	5.90	6.10	6.30	
C	5.04	5.34	5.64	
D	0.50	0.70	0.90	
E	9.00	9.30	9.60	
F	2.10	2.30	2.50	
G	0.66	0.76	0.86	
H	0.96 MAX			
I	2.20	2.30	2.40	
J	0.40	0.50	0.60	
K	1.60	1.80	2.00	
L	0.40	0.50	0.60	
M	0.72	1.02	1.32	
N	0.90	1.00	1.10	
O	1.50			